

TRUCK AND BUS TYRES

AEOLUS-TYRES.COM

AEOLUS

NO MATTER WHAT

NEO SERIES

04 About Aeolus Tyres

05 Hence Aeolus

06 NEO Series

08 Aeolus team

32 Steering axle patterns and sizes

34 Drive axle patterns and sizes

36 Trailer patterns and sizes

38 All positions patterns and sizes

40 Technical details

46 Regrooving

50 Size overview

09 NEO Allroads

NEO Allroads S
NEO Allroads S+
NEO Allroads D
NEO Allroads D+
NEO Allroads T
NEO Allroads T+

17 NEO Fuel

NEO Fuel S
NEO Fuel D
NEO Fuel T



21 NEO Construct

NEO Construct G
NEO Construct D

25 NEO Winter

NEO Winter S
NEO Winter D

29 NEO Urban

NEO Urban G



Ever since entering the European market (2004), we have been supplying tyres that offer the highest quality in their respective product segments. Tyres designed in accordance with European quality norms and ideal for the most demanding circumstances. We use high performance and the best price to guarantee our customers a low price per kilometre. **Aeolus. No matter what.**



Pirelli

We decided to take over Pirelli in 2017 in order to reinforce our position in the international tyre market. We thought it would be a good idea to harness the strengths of a large Asian brand with those of a renowned European brand. A smart move because it has put us in an even better position to meet the needs of the tyre market. A useful move because it has given a massive boost to our logistical & technological developments.

Total supplier

A tyre brand supplies tyres. Tyres in all sizes, with every pattern. Our products can be used anywhere for a variety of purposes. Truck and trailer tyres, OTR tyres, agricultural tyres, machine tyres, bus tyres, on and off-road tyres... you name it. This means you can do whatever you need, in all circumstances. Always.

Earth moving

Robust, top quality and hard-wearing: essential characteristics for tyres also those used during earth-moving activities. These tyres come with an hour-based guarantee, which (depending on the vehicle and use) guarantees a minimum number of operating hours. We also offer the market a comprehensive range, which is capable of meeting all customer needs. Our range of sizes and

AEOLUS TYRES

patterns, as well as our great price/quality ratio, takes care of the rest.

Agriculture

The agricultural sector is always on the move, which means so are we. It is nice to be a front-runner, when it comes to developing a wide range of tyres (specials) with strong casings and ingenious patterns, but nothing more than that. That is why we always examine what is going on around us: looking for opportunities and chasing innovations & developments. Because being a front-runner is about being smart. And you are smart if you remain on your toes and know what is happening in your surroundings. This is something we have always known.



Truck
Earth moving
Agriculture

Our tyres are for your benefit. For experts that know how rough outdoor terrains can be; for specialists familiar with the pain that accompanies bad roads. Day in, day out. That is why we develop the best performing, strongest and most innovative tyres. But also because we are able to. And when doing so, only the best is good enough. In a way, we see tyre patterns as the noise produced by a Harley Davidson. So stimulate, challenge or provoke us. We will do anything to achieve our ultimate goal: tyres for all weather conditions, all distances and all surfaces. **Aeolus. No matter what.**

NO MATTER WHAT



Quality

We develop and produce tyres in accordance with the international norms of renowned institutes and certifications. Our casing guarantee, as well as our partnership with Pirelli, guarantees high basic quality.



Availability

Just about all sizes and patterns are available from stock, which means our products are very easy to obtain. For instance, we always have 30,000 tyres in stock at our four different warehouses.



Price

With core competencies like quality, sustainability and quality, we are the leading alternative for renowned premium brands. The best price per kilometre takes care of the rest.



Sustainability

We continuously invest in environment-friendly production and comply with the ambitious norms of the 'Waste Zero Emission' label and the REACH programme.



Aeolus Breakdown Service (24/7)

Back on the road quickly after a puncture. Our Breakdown service will help you to get back on the road as soon as possible: 24 hours a day, 365 days a year, all throughout Europe. We help you to minimise lost time.



Service

Instead of empty promises, Aeolus offers proven quality: ranging from our qualified and helpful sales and service team, to our Aeolus Breakdown service all throughout Europe.



Wide range

We have a very wide range of products, which offers solutions for almost all purposes involving trucks, earth-moving machines, forestry & agricultural machines as well as special vehicles.



Research & development

Together with Pirelli, our engineers and technicians are always on the look-out for new ways to improve the tyres we offer, so they continue to meet the needs of the market.



Aeolus Casing Management

Environment-friendliness and sustainability pay dividends for transporters: casings that are suitable for tread renewal are purchased and useless casings are disposed of in accordance with applicable norms.

NEO SERIES

THE ULTIMATE TRUCK TYRE

The NEO series: produced in accordance with the latest technological developments and compliant with the strict needs and preferences of European users. Tyres that are perfectly in keeping with our ambition; to position Aeolus as a top tyre brand all across the globe. A series based on the perfect balance between research, design & technology.

How? By implementing the SATT casing structure and optimising rubber compounds: a great piece of innovation that allows kilometrages to be improved by 25%. Our partnership with Pirelli has been extremely valuable and given the NEO series a huge boost in the tyre market. The Ultimate Truck Tyre.



DLT/HSCC rubbercompound
European rubber compound with high silicone content, for high kilometrage and better grip on wet road surfaces.

SATT casing structure
Patented European 'SATT' casing design. The 3SB casing ensures uniform wear & tear and a long life-span.

FRC
Extremely strong 'Full Penetration' structure of belt layers, which prevents casing fatigue and offers excellent protection against punctures.

The NEO series are manufactured under a patent and know how license from **Pirelli Tyre**

HBW
Patented hexagonal bead wire. Offers better driving comfort and makes the tyre easier to mount.

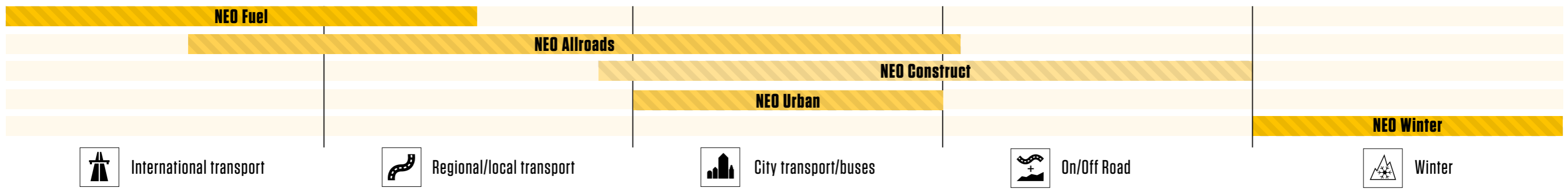

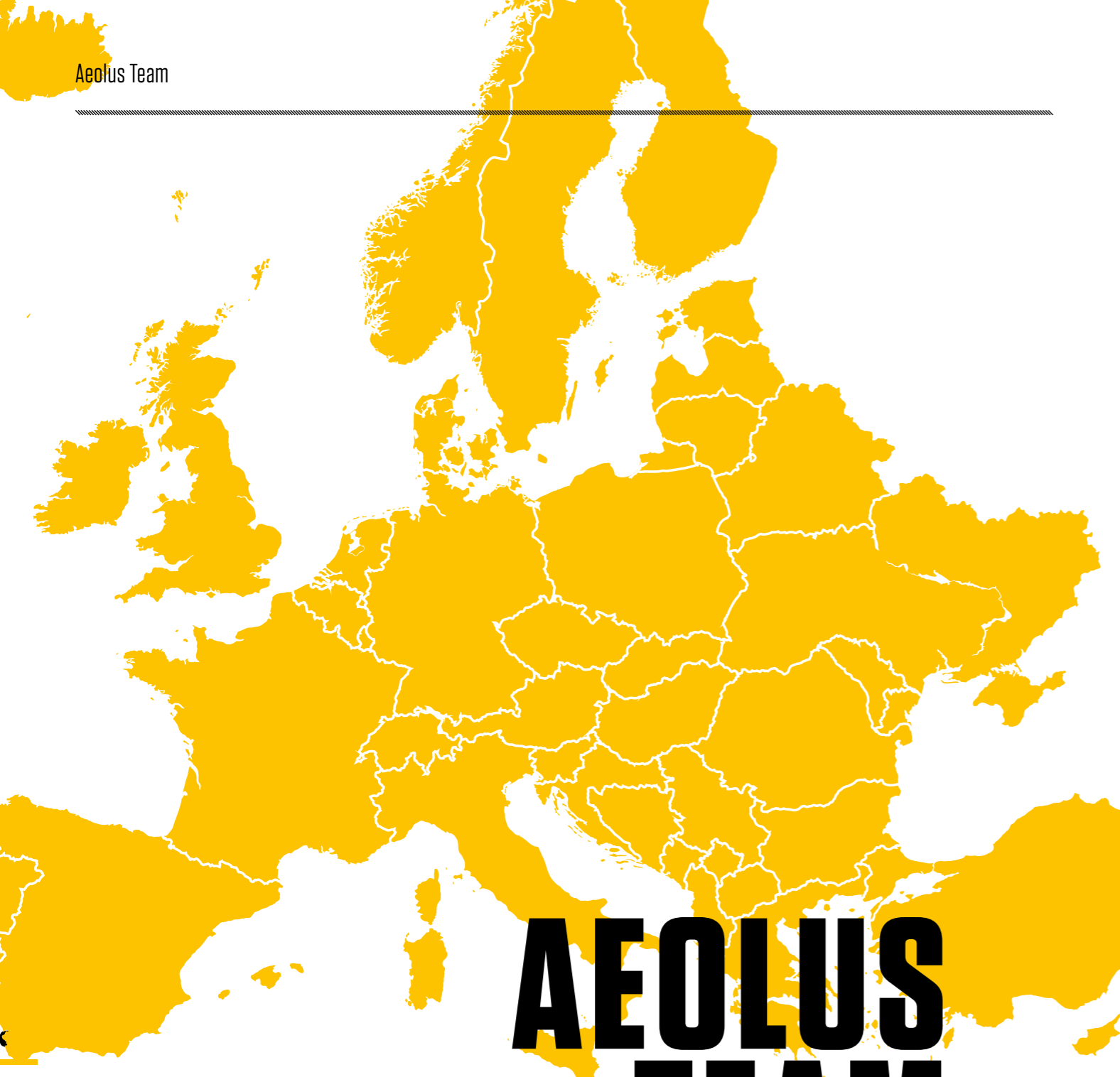

AEOLUS TEAM EUROPE

A top quality team is needed when developing and producing top quality tyres. Thankfully, we already have such a team. It's also good to know that our leading position is allowing us to attract the best people: professionals with the required expertise; people that value personal attention and pleasant customer contact.

Visit our website: www.aeolus-tyres.com

NEO ALLROADS

FIT FOR USAGE UNDER EVERY CONDITION,
ON ALL ROADS

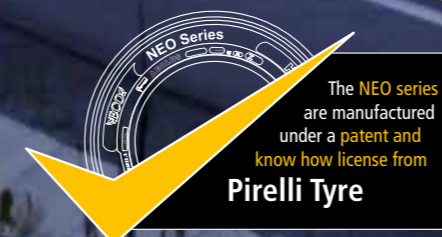

The NEO series are manufactured under a patent and know how license from Pirelli Tyre

AEOLUS

NO MATTER WHAT

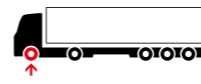
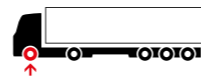

NEO ALLROADS S

- Suitable for Euro 6 legislation (High Load)
- Long life-span thanks to extra wide and extra deep pattern
- Safe driving and braking thanks to intelligent pattern with 4 Z-shaped longitudinal grooves
- Perfect handling on dry and wet surfaces thanks to refined pattern structure
- Noise-friendly due to optimised pattern design
- Ingenious rubber mix ensures balanced heat control
- Resistant against stone build-up due to interchanging pattern grooves

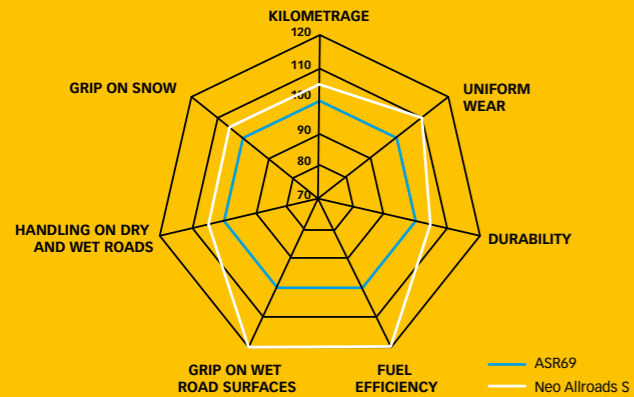

NEO ALLROADS S+

- Long life-span due to extra wide and extra deep pattern
- Safe driving and braking thanks to intelligent pattern with 4 Z-shaped longitudinal grooves
- Perfect handling on dry and wet surfaces thanks to refined pattern structure
- Resistant against stone build-up due to interchanging pattern grooves
- Extra belt layer reinforces casing and improves re-profiling
- Long life-span thanks to extra anti-wear layer in tread compound

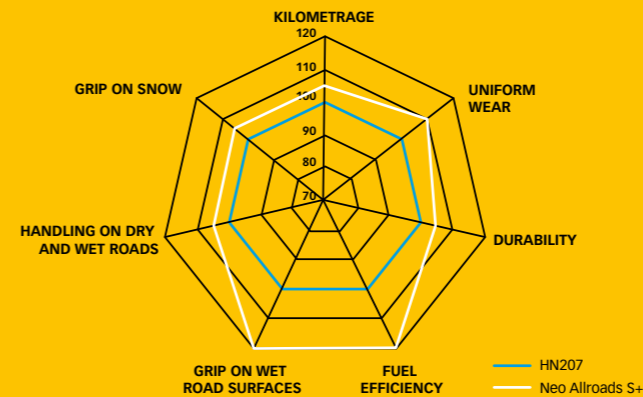

Size	L/S Index	TL/TT	M+S				DB	Class	Available
205/75R17.5	124/122M	TL	M+S						2018
215/75R17.5	126/124M	TL	M+S						2018
225/75R17.5	129/127M	TL	M+S						2018
235/75R17.5	132/130M	TL	M+S						2018
245/70R17.5	136/134M	TL	M+S						2018
265/70R19.5	140/138M	TL	M+S						2018
285/70R19.5	144/142M (145/143L)	TL	M+S						2018
295/60R22.5	149/146L (150/147K)	TL	M+S						2018
295/80R22.5	154/149M	TL	M+S						2018
315/70R22.5	156/150L (154/150M)	TL	M+S		B	B	73		Immediately
315/80R22.5	158/150L (154/150M)	TL	M+S						2018

Size	L/S Index	TL/TT	M+S				DB	Class	Available
385/55R22.5	160K (158L)	TL	M+S						2018
385/65R22.5	164K (158L)	TL	M+S		C	A	73		Immediately

NEO Allroads in the spotlight: Check out the NEO-series in at www.aeolus-tyres.com

010

011

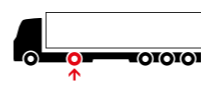

NEO ALLROADS D

- Suitable for regional distribution traffic
- High traction thanks to extra deep grooves with pattern featuring block design
- Pattern featuring inter-connected blocks extends life-span
- Extra quiet and comfortable thanks to sophisticated a-symmetrical block design
- Uniform wear thanks to reinforced shoulder design
- Extra belt layer reinforces casing and improves re-profiling
- Anti-wear layer in tread compound improves economy, noise and kilometrage

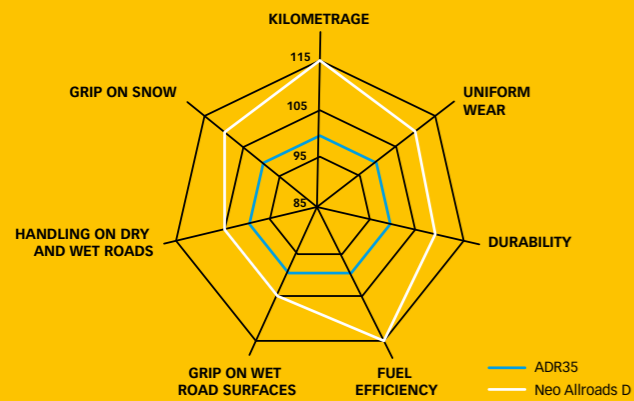

NEO ALLROADS D+

- Excellent life-span thanks to wider directional pattern design with deeper grooves
- Perfect handling on dry and wet surfaces thanks to refined pattern structure (3D sipes)
- Extra belt layer (FRC) reinforces casing, improves re-profiling and enables re-profiling
- Lasting high traction thanks to special groove design (sipes)
- Uniform wear thanks to reinforced shoulder design (RSR)
- Long life-span thanks to extra anti-wear layer in tread compound and special groove design (sipes)

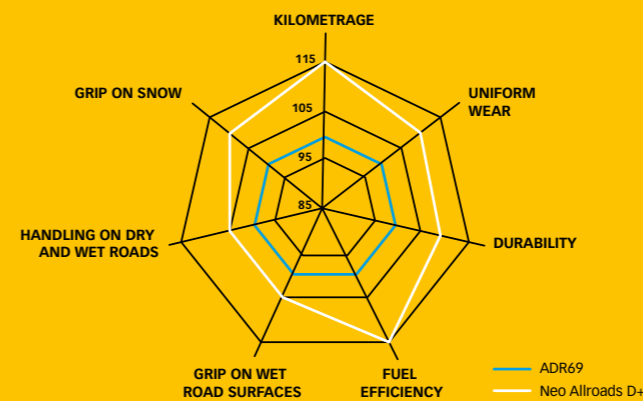

012

013

Size	L/S Index	TL/TT	M+S				DB	Class	Available
205/75R17.5	124/122M	TL	M+S						2018
215/75R17.5	126/124M	TL	M+S						2018
225/75R17.5	129/127M	TL	M+S						2018
235/75R17.5	132/130M	TL	M+S						2018
245/70R17.5	136/134M	TL	M+S						2018
265/70R19.5	140/138M	TL	M+S						2018
285/70R19.5	144/142M (145/143L)	TL	M+S		C	C	73		Immediately

Size	L/S Index	TL/TT	M+S				DB	Class	Available
295/60R22.5	149/146L (150/147K)	TL	M+S						2018
295/80R22.5	152/148M	TL	M+S						2018
315/60R22.5	152/148L	TL	M+S						2018
315/70R22.5	152/148M (154/150L)	TL	M+S		D	B	73		Immediately
315/80R22.5	154/150M (156/150L)	TL	M+S						2018

NEO Allroads in the spotlight:

Check out the NEO-series in at www.aeolus-tyres.com



NEO ALLROADS T

- Flatbed trailer tyre suitable for heavy loads
- Effective handling thanks to intelligent pattern with 4 Z-shaped longitudinal grooves
- Extra quiet and comfortable thanks to sophisticated a-symmetrical block design
- Resistant against stone build-up due to interchanging pattern grooves
- Uniform wear thanks to reinforced shoulder design
- Tread compound for low rolling resistance and effective heat discharge

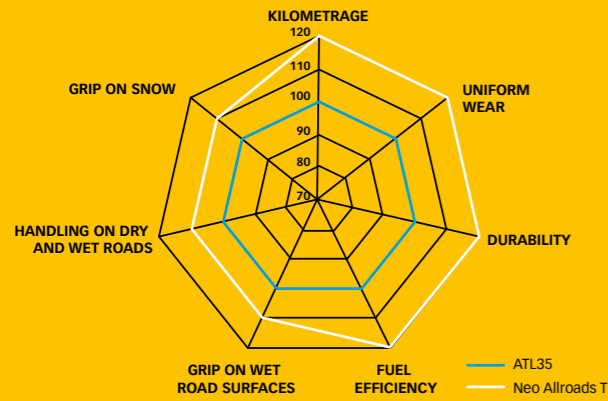

NEO ALLROADS T+

- Long life-span due to extra wide and extra deep pattern
- Effective handling thanks to intelligent pattern with 4 Z-shaped longitudinal grooves
- Extra quiet and comfortable thanks to sophisticated a-symmetrical block design
- Resistant against stone build-up due to interchanging pattern grooves
- Uniform wear thanks to reinforced shoulder design (RSR)
- Tread compound (DLT/HSCC) for low rolling resistance and effective heat discharge

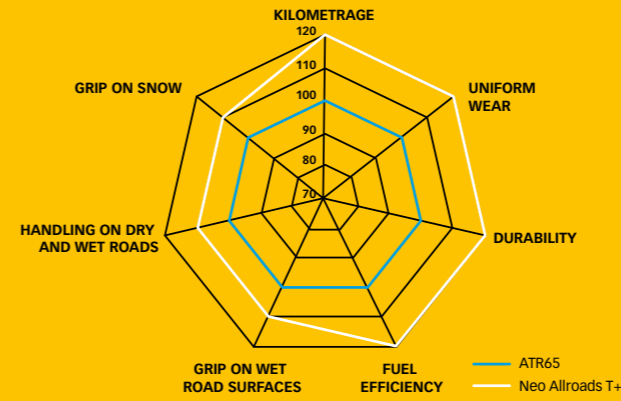

014

015

Size	L/S Index	TL/TT	M+S			DB	Class	Available
205/65R17.5	129/127J (132/132F)	TL	M+S		C C	71		2018
215/75R17.5	135/133J	TL	M+S					2018
235/75R17.5	143/141J (144/144F)	TL	M+S		C C	71		2018
245/70R17.5	143/141J (146/146F)	TL	M+S					2018
265/70R19.5	143/141J	TL	M+S					2018

Size	L/S Index	TL/TT	M+S			DB	Class	Available
285/70R19.5	150/147J	TL	M+S		C C	71		Immediately
385/55R22.5	160J (158L)	TL	M+S		B C	73		2018
385/65R22.5	164K (158L)	TL	M+S		B C	73		Immediately
425/65R22.5	165K	TL	M+S		C C	71		Immediately
445/65R22.5	169 K	TL	M+S		C C	71		Immediately

NEO Allroads in the spotlight:

Check out the NEO-series in at www.aeolus-tyres.com

Aeolus AR28

THE ULTIMATE HEAVY DUTY TYRE

NO MATTER WHAT.

ROBUST CASING STRUCTURE

SYMMETRICAL BLOCK PATTERN

SPECIAL RUBBER COMPOUND TECHNOLOGY



Size	L/S Index	TRA Code	Rim	Dimensions		Pattern depth(mm)	Air pressure (bar)
				Width	Diameter		
385/95R25	170F	E-2	10.00/1.5	389	1363	24	9,00
445/95R25	174F	E-2	11.25/2.0	444	1486	26	9,00

AEOLUS-TYRES.COM

NEO Series - The Ultimate Truck Tyre

NEO Fuel

NEO FUEL

LONG DISTANCE,
LESS FUEL

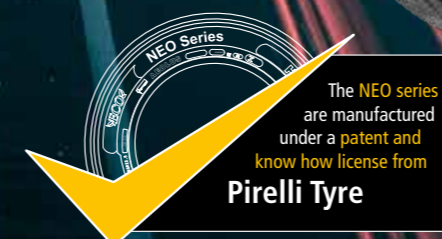

The NEO series are manufactured under a patent and know how license from Pirelli Tyre

AEOLUS

NO MATTER WHAT

017

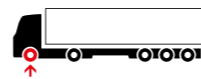

NEO FUEL S

- Suitable for Euro 6 legislation (High Load)
- Water discharge and handling thanks to pattern with connected blocks and 4 longitudinal grooves
- Temperature control at high speeds thanks to special groove design (sipes)
- Long life-span due to Z-shaped asymmetrical pattern that prevents stone build-up
- Anti-wear layer in tread compound improves fuel economy, kilometrage and life-span
- Full multi-layer structure makes casing strong and suitable for regrooving
- Uniform wear thanks to reinforced shoulder design

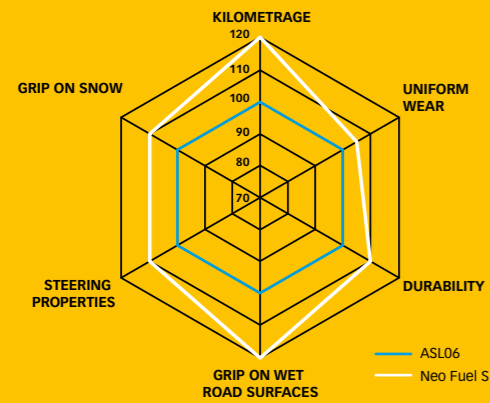

NEO FUEL D

- Drive axle tyre, specially designed for long distances
- Extremely high kilometrages and performance thanks to wide pattern
- High traction on wet and dry roads thanks to pattern with longitudinal grooves and block pattern
- Anti-wear layer in tread compound improves fuel economy, kilometrage and life-span
- Full multi-layer structure makes casing extra strong
- Two tread layers ensure long life-span and low fuel consumption

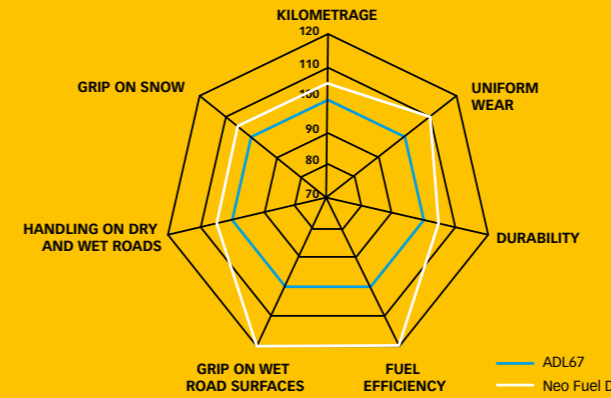

018

019

Size	L/S Index	TL/TT	M+S			DB	Class	Available
295/60R22.5	149/146L (150/147K)	TL	M+S		C D	72		Immediately
295/80R22.5	154/149M	TL	M+S		B B	72		Immediately
315/60R22.5	154/148L	TL	M+S					2018
315/70R22.5	156/150L (154/150M)	TL	M+S		B B	72		Immediately
315/80R22.5	158/150L (154/150M)	TL	M+S		B B	72		Immediately

Size	L/S Index	TL/TT	M+S			DB	Class	Available
295/60R22.5	149/146L (150/147K)	TL	M+S		D D	74		Immediately
295/80R22.5	152/148M	TL	M+S		D B	74		Immediately
315/60R22.5	152/148L	TL	M+S					2018
315/70R22.5	152/148M (154/150L)	TL	M+S		C B	74		Immediately
315/80R22.5	154/150M (156/150L)	TL	M+S		C B	74		Immediately

NEO Fuel in the spotlight:

Check out the NEO-series in at www.aeolus-tyres.com



NEO Fuel T+



NEO FUEL T+

- Trailer tyres, specially designed for international transport
- Perfect water and heat discharge thanks to pattern with connected blocks and 6 longitudinal grooves
- Uniform wear thanks to special shoulder design (RSR)
- Perfect grip and handling in bends on wet and dry roads thanks to unique pattern design
- Full multi-layer structure makes casing extra strong
- Special tread compound improves fuel economy on long journeys

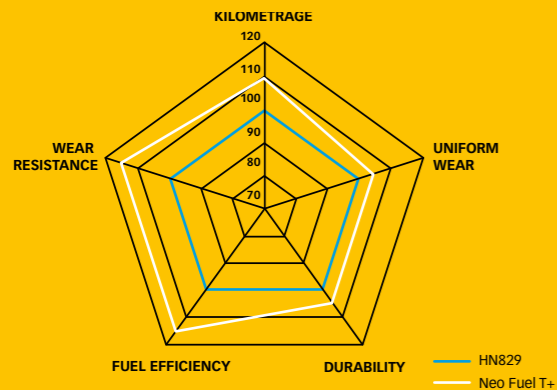

NEO Series - The Ultimate Truck Tyre

NEO Construct

NEO CONSTRUCT

THE BEST PERFORMING, THE LONGEST LASTING, THE STRONGEST



020

021

Size	L/S Index	TL/TT	M+S			DB	Class	Available
385/55R19.5	156J	TL	M+S					2018
385/65R22.5	164K	TL	M+S					2018
435/50R19.5	164J	TL	M+S		C D	72		Immediately
445/45R19.5	164J	TL	M+S		D C	73		2018

The NEO series are manufactured under a patent and know how license from Pirelli Tyre

AEOLUS

NO MATTER WHAT

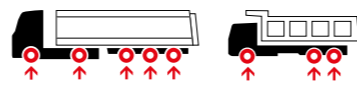

NEO CONSTRUCT G

- Excellent self-cleansing properties thanks to interchanging pattern design
- Minimum wear due to extremely stiff pattern design
- Special transverse grooves improve traction and prevent irregular wear
- Wider and deeper transverse grooves improve kilometrage
- Optimised heel and heel-core design for heavy loads
- Uniform wear thanks to special shoulder design
- Long life-span thanks to extra anti-wear layer



UNDER DEVELOPMENT

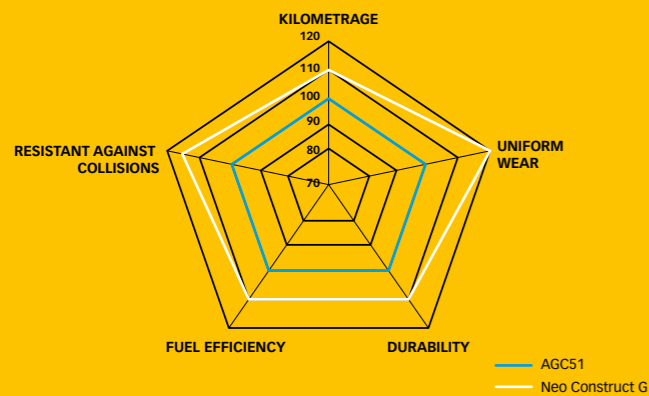

NEO CONSTRUCT D

- Extra wide and deep transversal grooves for perfect driving behaviour
- Extra-stiff tread thanks to block design featuring inter-connected blocks
- Advanced shoulder design offers maximum grip
- Optimised heel and heel-core design for heavy loads
- Excellent resistance against punctures and damage
- Uniform wear thanks to special shoulder design
- Long life-span thanks to extra anti-wear layer

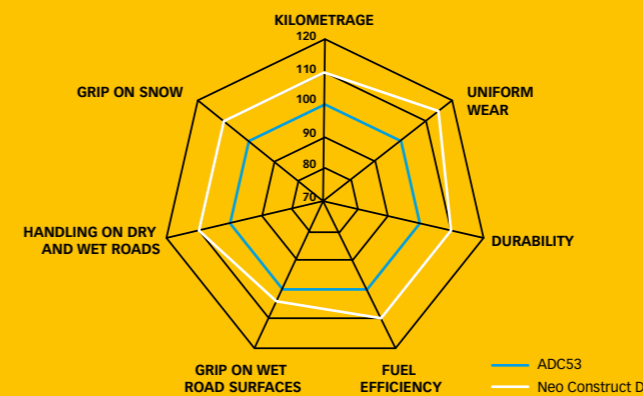

022

023

Size	L/S Index	TL/TT	M+S			DB	Class	Available
13R22.5	156/150K	TL	M+S					2019
315/80R22.5	156/150K (154/150M)	TL	M+S					2019
385/65R22.5	164K (158L)	TL	M+S					2019
425/65R22.5	165K	TL	M+S					2019
445/65R22.5	169 K	TL	M+S					2019
325/95R24	162/160K	TL	M+S					2019

Size	L/S Index	TL/TT	M+S			DB	Class	Available
13R22.5	156/150K	TL	M+S					2018
315/80R22.5	156/150K (154/150M)	TL	M+S					2018
325/95R24	162/160K	TL	M+S					2018

NEO Construct in the spotlight:

Check out the NEO-series in at www.aeolus-tyres.com

Aeolus AE77

THE ULTIMATE AGRICULTURE TYRE

NO MATTER WHAT.

Robust, durable and reliable? Check. Highly suitable for use on off-road vehicles & crashtenders? Check. Heavy loads and high speeds? No problem.



Size	L/S Index	TRA Code	Rim	Dimensions		Load capacity (kg) 80 km/h	Tyre pressure (kPa) 80 km/h	Pattern depth (mm)	TL/TT
				Width	Diameter				
24R20.5	176F	E-7	18.00	600	1370	7100	590	21	TL
525/65R20.5	173F	E-7	16.00	520	1200	6500	800	21	TL
445/65R22.5	169F	E-7	14.00	443	1149	5800	800	21	TL

AEOLUS-TYRES.COM

Neo Serie - The Ultimate Truck Tyre

NEO Winter

NEO WINTER

NOT MEANT FOR THE FAINT HEARTED



The NEO series are manufactured under a patent and know how license from **Pirelli Tyre**

AEOLUS
NO MATTER WHAT

025

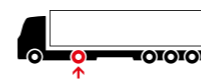
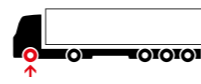

NEO WINTER S

- Suitable for Euro 6 legislation (High Load)
- Extreme traction due to innovative pattern design
- Special shoulder design ensures comfort and grip when steering
- Special winter-oriented rubber compound for grip in all circumstances

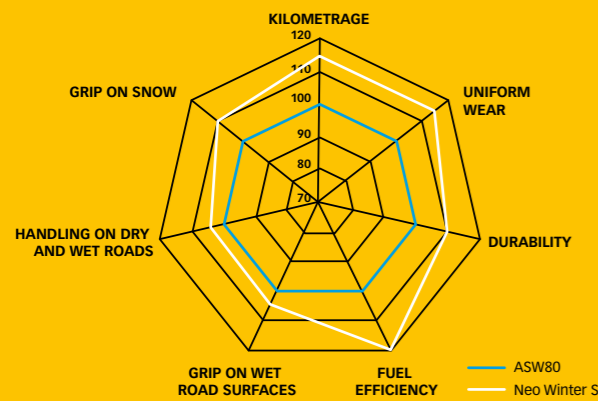

NEO WINTER D

- Drive axle tyre for winter conditions
- Perfect grip in snow, ice and wet conditions thanks to high-tech strip pattern (3D sipes)
- Extra belt layer (FRC) reinforces casing, improves re-profiling and enables re-profiling
- Lasting high traction thanks to special 3D pattern design
- Uniform wear thanks to reinforced shoulder design (RSR)
- Excellent life-span thanks to extra anti-wear layer in tread compound

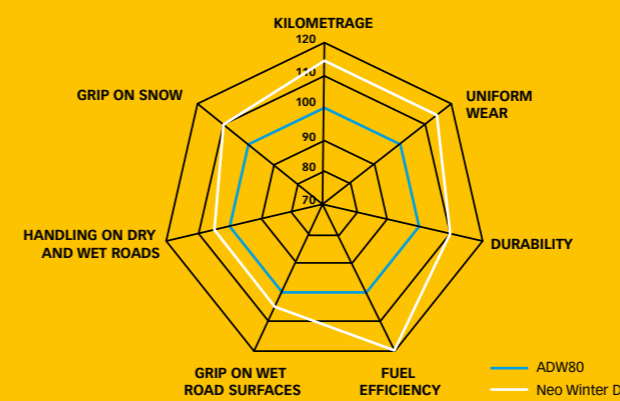

026

027

Size	L/S Index	TL/TT	M+S			DB	Class	Available
295/60R22.5	149/146L (150/147K)	TL	M+S					2019
295/80R22.5	154/149M	TL	M+S		D C	74		Immediately
315/60R22.5	154/148L	TL	M+S					2019
315/70R22.5	156/150L (154/150M)	TL	M+S					2019
315/80R22.5	158/150L (154/150M)	TL	M+S					2019
385/55R22.5	160K (158L)	TL	M+S					2019
385/65R22.5	164K (158L)	TL	M+S		D C	73		Immediately

Size	L/S Index	TL/TT	M+S			DB	Class	Available
295/60R22.5	149/146L (150/147K)	TL	M+S					2019
295/80R22.5	152/148M	TL	M+S					2019
315/60R22.5	152/148L	TL	M+S					2019
315/70R22.5	152/148M (154/150L)	TL	M+S		E C	74		Immediately
315/80R22.5	154/150M (156/150L)	TL	M+S					2019

NEO Winter in the spotlight:

Check out the NEO-series in at www.aeolus-tyres.com

**THE HARDER YOU PUNISH ME
THE MORE YOU CONTROL ME
THE EASIER YOU LET ULTIMATE
DRIVING LOOK**

NO MATTER WHAT.

Neo Serie - The Ultimate Truck Tyre

NEO Urban

NEO URBAN

BRAKE. PULL. GO. THE CITY IS YOURS.



AL59

AVAILABLE UP TO 33 INCH

AGC28

M+S

AEX1

MOBILE EXCAVATOR 10.00-20
DOUBLE ASSEMBLY

AEOLUS-TYRES.COM



The NEO series
are manufactured
under a patent and
know how license from
Pirelli Tyre

AEOLUS

NO MATTER WHAT

029



NEO URBAN G

- Tyre specifically for city buses and urban transport
- Deeper pattern for extra high kilometrage
- Better driving behaviour due to pattern with 4 longitudinal grooves
- Excellent heat discharge thanks to S-shaped design and special deep sipe design
- Extra-strong side wall protection minimises damage caused by pavements
- Low rolling resistance offers high kilometrages due to special silicone additive in compound
- Full multi-layer structure makes casing extra strong

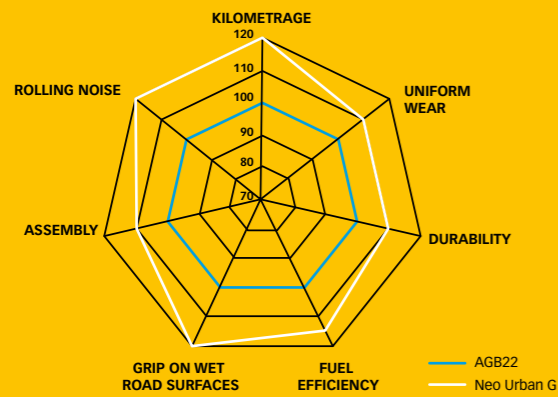

THE ONES THAT STRIKE YOU. A RANGE TO IMPRESS.

Size	L/S Index	TL/TT	M+S				DB	Class	Available
11R22.5	148/145J (151/148E)	TL	M+S						2019
275/70R22.5	148/145J (152/148E)	TL	M+S						2018
295/80R22.5	152/148J (154/150E)	TL	M+S						2019



ASR24



ASR35



HN257



ASL06



HN267



ASR69



HN227



ASW80



HN207



SIZE AND PATTERN OVERVIEW STEERING AXLE

Size	Pattern	M+S		TL/TT	L/S Index			DB	Class
9.5R17.5	ASR24	M+S		TL	129/127M	D	C	73	↔
205/75R17.5	ASR35	M+S		TL	124/122M	D	C	71	↔
215/75R17.5	ASR35	M+S		TL	127/124M	D	C	71	↔
225/75R17.5	ASR35	M+S		TL	129/127M	D	C	71	↔
235/75R17.5	ASR35	M+S		TL	132/129M	D	C	71	↔
245/70R17.5	ASR35	M+S		TL	136/134M	D	C	71	↔
265/70R19.5	HN257	M+S		TL	140/138M	D	C	73	↔
285/70R19.5	HN257	M+S		TL	144/142M (145/143L)	D	C	73	↔
9R22.5	ASL06	M+S		TL	136/134M	E	B	73	↔
10R22.5	HN257	M+S		TL	144/142M	C	C	73	↔
11R22.5	HN257	M+S		TL	146/143M	D	C	73	↔
12R22.5	HN257	M+S		TL	152/149M	D	C	73	↔
255/70R22.5	HN257	M+S		TL	140/137M (140/140L)	D	C	73	↔
275/70R22.5	HN257	M+S		TL	148/145M	C	C	73	↔
275/80R22.5	HN267	M+S		TL	149/146L (148/145M)	D	C	76	↔
295/60R22.5	NEO Fuel S	M+S		TL	149/146L (150/147K)	C	D	72	↔
295/60R22.5	HN257	M+S		TL	149/146L (150/147K)	D	C	73	↔
295/80R22.5	NEO Fuel S HL	M+S		TL	154/149M	B	B	72	↔
295/80R22.5	ASR69 HL	M+S		TL	154/149M	D	C	71	↔
295/80R22.5	NEO Winter S HL	M+S		TL	154/149M	D	C	74	↔
315/60R22.5	HN227	M+S		TL	152/148L	D	C	73	↔
315/70R22.5	NEO Allroads S HL	M+S		TL	156/150L (154/150M)	B	B	73	↔
315/70R22.5	NEO Fuel S HL	M+S		TL	156/150L (154/150M)	B	B	72	↔
315/70R22.5	ASR69 HL	M+S		TL	156/150L (154/150M)	D	C	72	↔
315/70R22.5	ASW80	M+S		TL	152/148M (154/150L)	D	C	73	↔
315/80R22.5	NEO Fuel S HL	M+S		TL	158/150L (154/150M)	B	B	72	↔
315/80R22.5	ASR69 HL	M+S		TL	158/150L (154/150M)	C	C	72	↔
315/80R22.5	ASW80	M+S		TL	154/150M (156/150L)	D	C	73	↔
385/55R22.5	ASW80	M+S		TL	160K (158L)	D	C	73	↔
385/65R22.5	NEO Allroads S+ HL	M+S		TL	164K (158L)	B	A	73	↔
385/65R22.5	HN207 HL	M+S		TL	164K (158L)	C	C	72	↔
385/65R22.5	NEO Winter S HL	M+S		TL	164K (158L)	D	C	73	↔

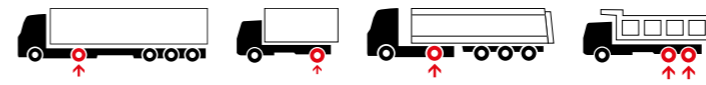

SIZE AND PATTERN OVERVIEW DRIVE AXLE

9.5R17.5	ADR35	M+S		TL	129/127M	E	C	73	↔
205/75R17.5	ADR35	M+S		TL	124/122M	E	C	73	↔
215/75R17.5	ADR35	M+S		TL	127/124M	E	C	73	↔
225/75R17.5	ADR35	M+S	⚠	TL	129/127M	E	C	73	↔
235/75R17.5	ADR35	M+S	⚠	TL	132/129M	E	C	73	↔
245/70R17.5	ADR35	M+S	⚠	TL	136/134M	E	C	73	↔
245/70R19.5	HN366+	M+S	⚠	TL	136/134M (136/135J)	E	C	76	↔
265/70R19.5	HN355	M+S	⚠	TL	140/138M	D	C	73	↔
285/70R19.5	ADR35	M+S	⚠	TL	144/142M (145/143L)	E	C	73	↔
285/70R19.5	NEO Allroads D	M+S		TL	144/142M (145/143L)	C	C	73	↔
12.00R20	ADC53	M+S	⚠	TT Set	154/151K	E	C	73	↔
10R22.5	HN355	M+S	⚠	TL	144/142M	D	C	73	↔
11R22.5	ADC53	M+S	⚠	TL	146/143L	E	B	73	↔
12R22.5	HN355	M+S	⚠	TL	152/149M	D	C	73	↔
12R22.5	ADC53	M+S	⚠	TL	152/149L	D	C	71	↔
13R22.5	HN352	M+S	⚠	TL	154/151K (156/150G)	D	B	73	↔
13R22.5	ADC53	M+S	⚠	TL	154/151K (156/150G)	D	C	73	↔
255/70R22.5	HN355	M+S	⚠	TL	140/137M (140/140L)	D	C	73	↔
275/70R22.5	HN355	M+S	⚠	TL	148/145M	D	C	73	↔
275/80R22.5	HN306	M+S	⚠	TL	149/146L (148/145M)	D	C	76	↔
295/60R22.5	NEO Fuel D	M+S	⚠	TL	149/146L (150/147K)	D	D	74	↔
295/60R22.5	HN355	M+S	⚠	TL	149/146L (150/147K)	D	C	73	↔
295/60R22.5	ADL67	M+S		TL	149/146L (150/147K)	E	C	73	↔
295/80R22.5	NEO Fuel D	M+S	⚠	TL	152/148M	D	B	74	↔
295/80R22.5	ADR69	M+S	⚠	TL	152/148M	E	C	74	↔
295/80R22.5	ADW80	M+S	⚠	TL	152/148M	F	C	73	↔
315/60R22.5	ADL67	M+S	⚠	TL	152/148L	E	C	73	↔
315/70R22.5	NEO Allroads D+	M+S	⚠	TL	152/148M (154/150L)	D	B	73	↔
315/70R22.5	NEO Fuel D	M+S	⚠	TL	152/148M (154/150L)	C	B	74	↔
315/70R22.5	ADR69	M+S	⚠	TL	152/148M (154/150L)	D	C	74	↔
315/70R22.5	ADL67	M+S	⚠	TL	152/148M (154/150L)	C	C	73	↔
315/70R22.5	NEO Winter D	M+S	⚠	TL	152/148M (154/150L)	E	C	74	↔
315/80R22.5	NEO Fuel D	M+S	⚠	TL	154/150M (156/150L)	C	B	74	↔
315/80R22.5	ADR69	M+S	⚠	TL	154/150M (156/150L)	D	C	74	↔
315/80R22.5	ADL67	M+S	⚠	TL	154/150M (156/150L)	D	C	73	↔
315/80R22.5	ADC53	M+S	⚠	TL	154/150M (156/150L)	C	C	73	↔
315/80R22.5	HN352	M+S	⚠	TL	156/150K	D	B	72	↔
315/80R22.5	ADW80	M+S	⚠	TL	154/150M (156/150L)	F	C	73	↔
12.00R24	ADC53	M+S	⚠	TT Set	160/157K	E	C	73	↔



HN230+



ATL35



ATR65



HN828+



HN829



HN809



SIZE AND PATTERN OVERVIEW TRAILER

Size	Pattern	M+S		TL/TT	L/S Index			DB	Class
8.25R15	HN230+	M+S		TT Set	143/141G (141/140J)	C	C	73	↔
10.00R15	HN230+	M+S		TT Set	148/145G (146/144J)	C	C	73	↔
205/65R17.5	NEO Allroads T	M+S		TL	129/127J (132/132F)	C	C	71	↔
215/75R17.5	ATL35	M+S		TL	135/133J	D	D	73	↔
235/75R17.5	NEO Allroads T	M+S		TL	143/141J (144/144F)	C	C	71	↔
235/75R17.5	ATL35	M+S		TL	143/141J (144/144F)	D	D	73	↔
245/70R17.5	ATR65	M+S		TL	143/141J (146/146F)	C	C	73	↔
245/70R19.5	HN828+	M+S		TL	141/140J	D	C	76	↔
265/70R19.5	ATR65	M+S		TL	143/141J	C	C	73	↔
285/70R19.5	ATR65	M+S		TL	150/147J	C	C	73	↔
285/70R19.5	NEO Allroads T+	M+S		TL	150/147J	C	C	71	↔
385/55R19.5	ATR65	M+S		TL	156J	C	C	73	↔
435/50R19.5	HN829	M+S		TL	160J	D	C	73	↔
435/50R19.5	NEO Fuel T+	M+S		TL	164J	C	D	72	↔
445/45R19.5	HN829	M+S		TL	160J	D	C	73	↔
385/55R22.5	NEO Allroads T+	M+S		TL	160J (158L)	B	C	73	↔
385/55R22.5	ATR65	M+S		TL	160J (158L)	C	C	73	↔
385/65R22.5	NEO Allroads T+ HL	M+S		TL	164K (158L)	B	C	73	↔
385/65R22.5	ATR65	M+S		TL	160K (158L)	B	C	73	↔
385/65R22.5	ATR65+ HL	M+S		TL	164K (158L)	B	C	73	↔
385/65R22.5	HN809	M+S		TL	160K (158L)	C	C	72	↔
425/65R22.5	NEO Allroads T+	M+S		TL	165K	C	C	71	↔
425/65R22.5	ATR65	M+S		TL	165K	B	C	73	↔
445/65R22.5	NEO Allroads T+	M+S		TL	169 K	C	C	71	↔
445/65R22.5	ATR65	M+S		TL	169 K	B	C	73	↔



HN08



AGC28



AGB20



AGC51



HN253



HN10



AGB22

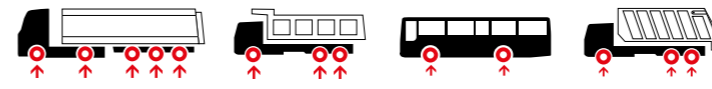

SIZE AND PATTERN OVERVIEW ALL POSITIONS

Size	Pattern	M+S		TL/TT	L/S Index			DB	Class
7.50R16	HN08	M+S		TT Set	122/118L	E	C	71	↔
8.25R16	HN08	M+S		TT Set	126/122L	E	C	71	↔
215/75R17.5	AGC28	M+S		TL	135/133J	E	C	73	↔
235/75R17.5	AGC28	M+S		TL	143/141J (144/144F)	E	C	73	↔
245/70R17.5	AGC28	M+S		TL	143/141J (144/144F)	E	C	73	↔
265/70R19.5	AGC28	M+S		TL	143/141J	E	C	73	↔
8.25R20	HN08	M+S		TT Set	136/134K	E	C	71	↔
9.00R20	HN08	M+S		TT Set	144/142K	D	C	71	↔
10.00R20	HN08	M+S		TT Set	146/143K	D	C	71	↔
11.00R20	HN08	M+S		TT Set	149/145K	D	C	71	↔
12.00R20	HN08	M+S		TT Set	154/149K	D	C	71	↔
11R22.5	HN08	M+S		TL	146/143L	D	C	71	↔
11R22.5	AGB20+	M+S		TL	148/145J (151/148E)	D	C	73	↔
12R22.5	HN08	M+S		TL	152/149L	C	C	71	↔
13R22.5	AGC51	M+S		TL	154/151L (156/150K)	D	C	73	↔
13R22.5	HN253	M+S		TL	154/151L (156/150K)	D	C	71	↔
13R22.5	HN10	M+S		TL	154/151G (156/150F)	E	C	76	↔
275/70R22.5	AGC28	M+S		TL	148/145L	E	C	73	↔
275/70R22.5	AGB20	M+S		TL	148/145J (152/148E)	D	C	73	↔
275/70R22.5	NEO Urban G	M+S		TL	148/145J (152/148E)	D	C	73	↔
295/80R22.5	AGB20	M+S		TL	152/148J (154/150E)	D	C	73	↔
305/70R22.5	AGB22	M+S		TL	152/150L	D	E	73	↔
315/80R22.5	AGC51	M+S		TL	154/150L (156/150K)	C	C	73	↔
315/80R22.5	HN08	M+S		TL	154/150L (156/150K)	C	C	71	↔
385/55R22.5	AGC28	M+S		TL	160K (158L)	C	C	73	↔
385/65R22.5	AGC28	M+S		TL	160K (158L)	C	C	73	↔
425/65R22.5	AGC28	M+S		TL	165K	C	C	73	↔
445/65R22.5	AGC28	M+S		TL	169 K	C	C	73	↔
12.00R24	AGC51	M+S		TT Set	160/157K	D	C	73	↔
12.00R24	HN08	M+S		TT Set	160/157K	C	C	71	↔

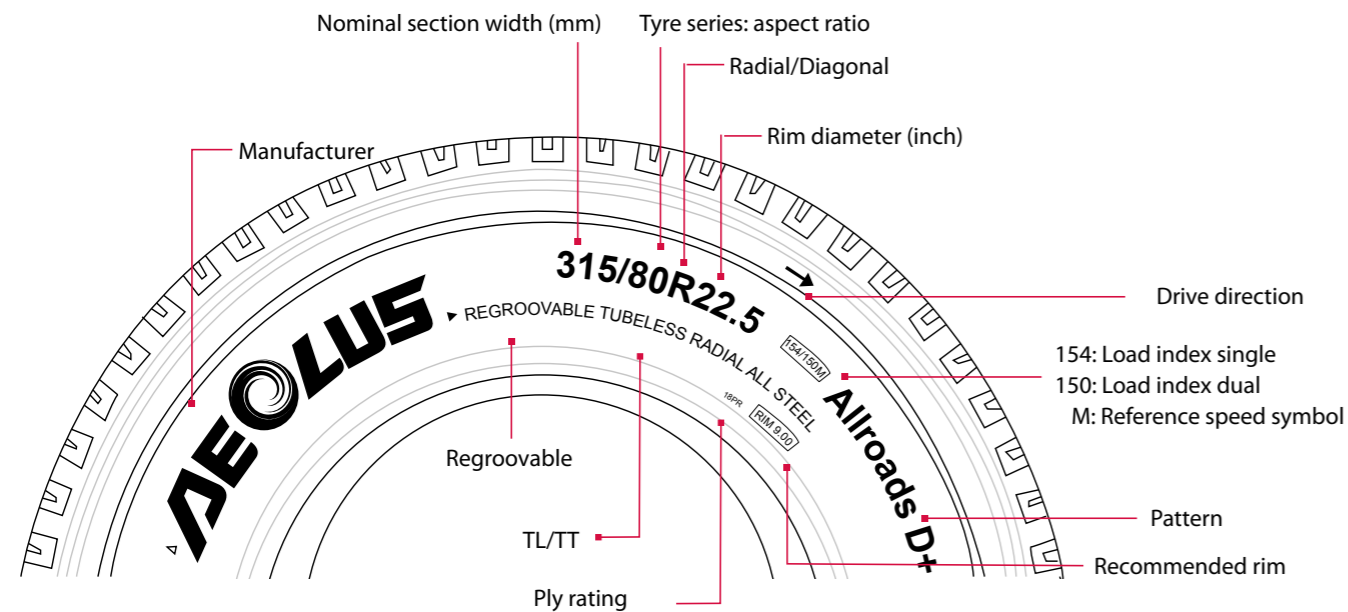

TECHNICAL SPECIFICATIONS

- A** External diameter
- B** Width
- H** Loaded radius
- F** Rim diameter
- Q** Cross section
- Z** Minimum distance, twin tyres

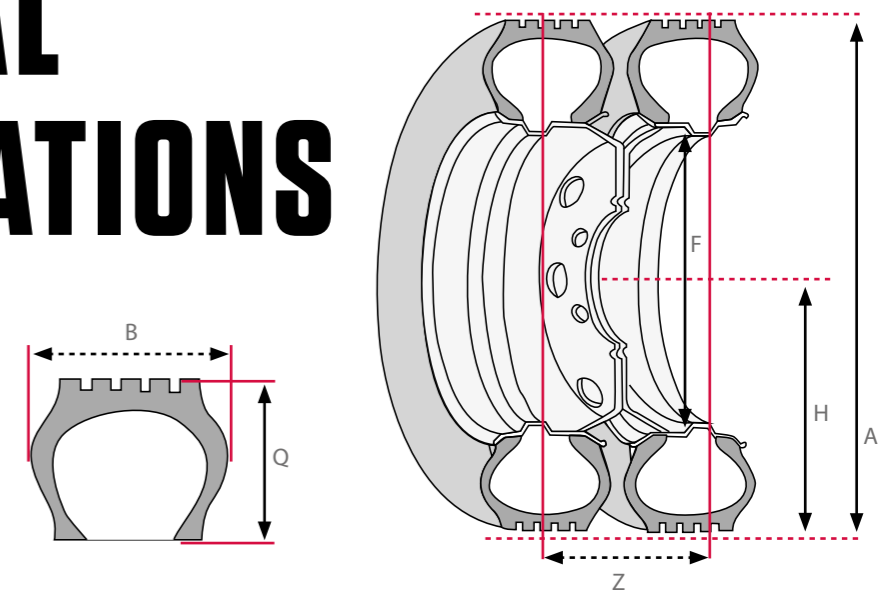

LOAD INDEX

Loadindex	Loading capacity in kg
120	1400
121	1450
122	1500
123	1550
124	1600
125	1650
126	1700
127	1750
128	1800
129	1850
130	1900
131	1950
132	2000
133	2060
134	2120
135	2180
136	2240
137	2300
138	2360
139	2430
140	2500
141	2575
142	2650
143	2725
144	2800
145	2900
146	3000
147	3075
148	3150
149	3250
150	3350
151	3450
152	3550
153	3650
154	3750

SPEED INDEX

Speed symbol	Speed in km
F	80
G	90
J	100
K	110
L	120
M	130
N	140

DEVIATIONS IN LOAD CAPACITY DEPENDING ON SPEED

The data shown directly below in the table on this page correspond to the international ETRTO standard and are intended only to provide information for the reader.

Always contact us by telephone or e-mail in special cases – in the case of cargoes which exceed explicit load limits as indicated on the side wall of the tyre in question or as specified in the instructions in this catalogue. In all cases in which the necessary air pressure in the tyres has to be increased to more than 10 bar on the basis of the data supplied here: Reduce the weight of your intended cargo until you are able to drive with a maximum pressure of 10 bar. If despite

this there is still a need to drive with a pressure in excess of 10 bar, as well as carrying out the basically essential check with us, you will also need to check the specified limits of the applicable rim manufacturer, as well as expressly following the regulations for fitment and use of both the components in question (tyres and wheels).

In addition, the following tyre loading capacities are applicable in special cases: Buses and coaches (M3 class 1): + 15% loading capacity if the average speed is below 40 km/h. Buses and coaches (M3 class 2): + 10% loading capacity if the average speed remains below 60 km/h.

Speed (km/h) Speed Symbol	Speed in km						Pressure compensation (%)
	F	G	J	K	L	M	
0	+150	+150	+150	+150	+150	+150	40
5	+110	+110	+110	+110	+110	+110	40
10	+80	+80	+80	+80	+80	+80	30
15	+65	+65	+65	+65	+65	+65	25
20	+50	+50	+50	+50	+50	+50	21
25	+35	+35	+35	+35	+35	+35	17
30	+25	+25	+25	+25	+25	+25	13
35	+19	+19	+19	+19	+19	+19	11
40	+15	+15	+15	+15	+15	+15	10
45	+13	+13	+13	+13	+13	+13	9
50	+12	+12	+12	+12	+12	+12	8
55	+11	+11	+11	+11	+11	+11	7
60	+10	+10	+10	+10	+10	+10	6
65	+7.5	+8.5	+8.5	+8.5	+8.5	+8.5	4
70	+5.0	+7.0	+7.0	+7.0	+7.0	+7.0	2
75	+2.5	+5.5	+5.5	+5.5	+5.5	+5.5	1
80	(0)	4.0	+4.0	+4.0	+4.0	+4.0	0
85		2.0	+3.0	+3.0	+3.0	+3.0	0
90		(0)	+2.0	+2.0	+2.0	+2.0	0
95			+1.0	+1.0	+1.0	+1.0	0
100			(0)	0	0	0	0
110				(0)	0	0	0
120					(0)	0	0
130						(0)	0

Size	Pattern	L/S-index	L/S-index 2	PR	TL/TT	M+S	Width (mm)	External diam. (mm)	Loaded radius (mm)	Rolling circ. (mm)	Tread depth (mm)	Rim	Perm. rims	Bearing capacity per tyre		Bearing capacity per axle		Tyre pressure (bar)	Weight (kg)	Rolling resistance	Wet Grip	Noise Emission (dB)	Noise Emission (Class)	Vehicle class
														Single	Dual	Single	Dual							
8.25R15	HN230+	143/141G	141/140J	18	TT SET	M+S	237	834	374	2544	13.0	6.5 - 15		2725	2575	2575	2500	8.5	32.9	C	C	73	CAT-2	C3
10.00R15	HN230+	148/145G	146/144J	18	TT SET	M+S	279	923	410	2815	13.5	7.5 - 15	7.0, 8.0 - 15	3150	2900	3000	2800	8.5	48.55	C	C	73	CAT-2	C3
7.50R16	HN08	122/118L		14	TT SET		216	803	784	2449	13.0	6.00G - 16	5.50f - 16, 6.50H - 16	1500	1320			7.7	33.01	E	C	71	CAT-2	C3
8.25R16	HN08	126/122L		14	TT SET	M+S	230	850	851	2593	13.0	6.50H - 16	6.00G - 16, 6.5 - 16	1700	1500			6.7	37.93	E	C	71	CAT-2	C3
9.5R17.5	ASR24	136/134M		18	TL	M+S	230	844	385	2574	13.0	6.75 - 17.5	6.00 - 17.5	2240	2120			9.0	45.1	D	C	73	CAT-2	C3
9.5R17.5	ADR35	136/134M		18	TL	M+S	234	851	385	2596	16.0	6.75 - 17.5	6.00 - 17.5	2240	2120			9.0	45.1	E	C	73	CAT-1	C3
205/75R17.5	ASR35	124/122M		14	TL	M+S	208	754	351	2294	13.0	6.00 - 17.5	6.75 - 17.5	1600	1500			7.6	27.46	D	C	71	CAT-1	C3
205/75R17.5	ADR35	124/122M		14	TL	M+S	205	760	351	2384	16.0	6.00 - 17.5	6.75 - 17.5	1600	1500			7.6	27.89	E	C	73	CAT-1	C3
215/75R17.5	ASR35	127/124M		16	TL	M+S	216	765	347	2327	13.0	6.00 - 17.5	6.75 - 17.5	1750	1600			8.3	28.2	D	C	71	CAT-1	C3
215/75R17.5	ADR35	127/124M		16	TL	M+S	215	770	360	2349	16.0	6.00 - 17.5	6.75 - 17.5	1750	1600			8.3	28.92	E	C	73	CAT-1	C3
215/75R17.5	ATL35	135/133J		18	TL	M+S	216	765	347	2318	12.0	6.00 - 17.5	6.75 - 17.5	2180	2060			8.3	28.2	D	D	73	CAT-2	C3
215/75R17.5	AGC28	135/133J		18	TL	M+S	218	766	347	2327	15.5	6.00 - 17.5	6.75 - 17.5	2180	2060			8.3	29.36	E	C	73	CAT-2	C3
225/75R17.5	ASR35	129/127M		16	TL	M+S	224	779	368	2391	13.0	6.75 - 17.5	7.50 - 17.5	1850	1750			8.3	29.85	D	C	71	CAT-1	C3
225/75R17.5	ADR35	129/127M		16	TL	M+S	222	784	368	2391	17.0	6.75 - 17.5	7.50 - 17.5	1850	1750			8.3	30.29	E	C	73	CAT-1	C3
235/75R17.5	ASR35	132/129M		16	TL	M+S	235	793	370	2419	13.0	6.75 - 17.5	7.50 - 17.5	2000	1850			8.3	30.49	D	C	71	CAT-1	C3
235/75R17.5	ADR35	132/129M		16	TL	M+S	236	800	370	2440	17.0	6.75 - 17.5	7.50 - 17.5	2000	1850			8.3	31.8	E	C	73	CAT-1	C3
235/75R17.5	ATL35	143/141J	144/144F	18	TL	M+S	236	793	365	2419	13.0	6.75 - 17.5	7.50 - 17.5	2725	2575	2800	2800	8.3	31.1	D	D	73	CAT-2	C3
235/75R17.5	NEO ALLROADS T	143/141J	144/144F	18	TL	M+S	236	793	365	2419	13.0	6.75 - 17.5	7.50 - 17.5	2725	2575	2800	2800	8.3	31.1	C	C	71	CAT-2	C3
235/75R17.5	AGC28	143/141J	144/144F	18	TL	M+S	236	804	370	2440	16.5	6.75 - 17.5	7.50 - 17.5	2725	2575	2800	2800	9.0	32.68	E	C	73	CAT-2	C3
245/70R17.5	ASR35	136/134M		18	TL	M+S	251	787	356	2400	13.0	6.75 - 17.5	7.50 - 17.5	2240	2120			9.0	33.61	D	C	71	CAT-1	C3
245/70R17.5	ADR35	136/134M		18	TL	M+S	250	791	356	2412	16.5	6.75 - 17.5	7.50 - 17.5	2240	2120			9.0	34.68	E	C	73	CAT-1	C3
245/70R17.5	ATR65	143/141J	146/146F	18	TL	M+S	252	780	356	2379	11.0	6.75 - 17.5	7.50 - 17.5	2725	2575	2800	2800	9.0	33.08	C	C	73	CAT-2	C3
245/70R17.5	AGC28	143/141J	144/144F	18	TL	M+S	252	793	356	2418	16.5	6.75 - 17.5	7.50 - 17.5	2725	2575	2800	2800	9.0	35.4	E	C	73	CAT-2	C3
245/70R19.5	HN366+	136/134M	136/135J	16	TL	M+S	252	844	382	2574	17.0	7.50 - 19.5	6.75 - 19.5	2240	2120	2240	2180	7.6	37.26	E	C	76	CAT-2	C3
245/70R19.5	HN828+	141/140J		18	TL	M+S	252	838	382	2556	13.5	7.50 - 19.5	6.75 - 19.5	2575	2500			8.3	36.24	D	C	76	CAT-3	C3
265/70R19.5	HN257	140/138M		16	TL	M+S	258	869	400	2650	13.0	7.50 - 19.5	8.25 - 19.5	2500	2360			8.3	38.67	D	C	73	CAT-2	C3
265/70R19.5	HN355	140/138M		16	TL	M+S	255	874	400	2665	16.5	7.50 - 19.5	8.25 - 19.5	2500	2360			8.3	40.12	D	C	73	CAT-1	C3
265/70R19.5	ATR65	143/141J		18	TL	M+S	256	866	400	2641	13.0	7.50 - 19.5	8.25 - 19.5	2725	2575			8.3	38.67	C	C	73	CAT-2	C3
265/70R19.5	AGC28	143/141J		18	TL	M+S	258	877	400	2674	17.5	7.50 - 19.5	8.25 - 19.5	2725	2575			8.3	41.12	E	C	73	CAT-2	C3
285/70R19.5	HN257	144/142M	145/143L	16	TL	M+S	278	890	406	2796	14.0	7.50 - 19.5	8.25 - 19.5	2800	2650	2900	2725	8.3	41.7	D	C	73	CAT-2	C3
285/70R19.5	ADR35	144/142M	145/143L	16	TL	M+S	276	896	415	2733	17.0	7.50 - 19.5	8.25 - 19.5	2800	2650	2900	2725	8.3	42.4	E	C	73	CAT-1	C3
285/70R19.5	NEO ALLROADS D	146/144L	145/143M	18	TL	M+S	285	894	414	2727	16.0	7.50 - 19.5	8.25 - 19.5	3000	2800	2900	2725	8.5	41.9	C	C	73	CAT-1	C3
285/70R19.5	ATR65	150/147J		18	TL	M+S	279	891	406	2797	14.0	7.50 - 19.5	8.25 - 19.5	3350	3075			8.3	41.7	C	C	73	CAT-2	C3
285/70R19.5	NEO ALLROADS T+	150/148J		18	TL	M+S	279	891	406	2797	12.5	7.50 - 19.5	8.25 - 19.5	3350	3150			9.0	41.5	C	C	71	CAT-2	C3
385/55R19.5	ATR65	156J		18	TL	M+S	386	924	423	2800	15.0	11.75 - 19.5	12.25 - 19.5	4000				9.0	66.39	C	C	73	CAT-2	C3
435/50R19.5	HN829	160J		20	TL	M+S	425	928	430	2812	15.0	14.00 - 19.5		4500				9.0	69.19	D	C	73	CAT-2	C3
435/50R19.5	NEO FUEL T+	164J		20	TL	M+S	429	922	427	2834	12.0	14.00 - 19.5		5000				9.0	65.74	C	D	72	CAT-2	C3
445/45R19.5	HN829	160J		22	TL	M+S	446	900	414	2727	15.5	14.00 - 19.5		4500				9.0	75.1	D	C	73	CAT-2	C3
8.25R20	HN08	136/134K		14	TT SET	M+S	232	965	452	2943	14.5	6.5 - 20	6.50T - 20,	2240	2120			8.3	46.73	E	C	71	CAT-2	C3
9.00R20	HN08	144/142K		16	TT SET	M+S	256	1025	475	3126	15.5	7.00 - 20	7.00T 7.5 - 20	2800	2650			9.0	54.32	D	C	71	CAT-2	C3
10.00R20	HN08	146/143K		16	TT SET	M+S	274	1054	480	3214	16.5	7.5 - 20	7.50V 8.0 - 20	3000	2725			8.3	60.54	D	C	71	CAT-2	C3
11.00R20	HN08	149/145K		16	TT SET	M+S	287	1088	502	3417	17.0	8.0 - 20	8.00V 8.5 - 20	3250	2900			8.3	68.88	D	C	71	CAT-2	C3
12.00R20	HN08	154/149K		18	TT SET	M+S	310	1122	518	3422	17.5	8.5 - 20	8.50V 9.0 - 20	3750	3250			8.3	80.47	D	C	71	CAT-2	C3
12.00R20	ADC53	154/151K		18	TT SET	M+S	310	1130	518	3422	20.6	8.5 - 20	8.50V 9.0 - 20	3750	3450			8.3	82.16	E	C	73	CAT-1	C3
9R22.5	ASL06	136/134M		14	TL	M+S	227	966	439	2952	14.5	6.75 - 22.5	7.50 - 22.5	2240	2120			8.3	42.7	C	B	73	CAT-2	C3
10R22.5	HN257	144/142M		16	TL	M+S	248	1020	475	3117	14.5	7.50 - 22.5	6.75 - 22.5	2800	2650			9.0	48.24	C	C	73	CAT-2	C3
10R22.5	HN355	144/142M		16	TL	M+S	258	1025	476	3126	15.5	7.50 - 22.5	6.75 - 22.5	2800	2650			9.0	47.97	D	C	73	CAT-1	C3
11R22.5	HN257	146/143M	148/145L	16	TL	M+S	277	1051	491	3206	15.0	8.25 - 22.5	7.50 - 22.5	3000	2725	3150	2900	8.3	56.55	D	C	73	CAT-2	C3
11R22.5	HN08	146/143L	148/145K	16	TL	M+S	281	1054	491	3215	16.5	8.25 - 22.5	7.50 - 22.5	3000	2725	3150	2900	8.3	56.62	D	C	71	CAT-2	C3
11R22.5	ADC53	146/143L	148/145K	16	TL	M+S	281	1066	491	3348	22.5	8.25 - 22.5	7.50 - 22.5	3000	2725	3150	2900	8.3	62.52	E	B	73	CAT-1	C3
11R22.5	AGB20+	148/145J	151/148E	16	TL	M+S	284	1062	491	3239	20.0	8.25 - 22.5	7.50 - 22.5	3150	2900	3450	3150	8.3	61.97	C	C	73	CAT-2	C3
12R22.5	HN257	152/149M		18	TL		300	1076	507	3282	16.5	9.00 - 22.5	8.25 - 22.5	3550	3250			9.3	62.15	D	C	73	CAT-2	C3
12R22.5	HN08	152/149L		18	TL		300	1076	507	3282	17.0	9.00 - 22.5	8.25 - 22.5	3550	3250			9.3	65.14	D	C	71	CAT-2	C3
12R22.5	ADC53	152/149L		18	TL	M+S	300	1081	507	3282	19.5	9.00 - 22.5	8.25 - 22.5	3550	3250			9.3	66.54	E	C	73	CAT-1	C3
12R22.5	HN355	152/149M		18	TL	M+S	300	1091	507	3282	23.0	9.00 - 22.5	8.25 - 22.5	3550	3250			9.3	69.68	D	C	73	CAT-1	C3
13R22.5	AGC51	154/151L	156/150K	18	TL	M+S	316	1128	532	344														

Size	Pattern	L/S-index	L/S-index 2	PR	TL/TT	M+S	Width (mm)	External diam. (mm)	Loaded radius (mm)	Rolling circ. (mm)	Tread depth (mm)	Rim	Perm. rims	Bearing capacity per tyre		Bearing capacity per axle		Tyre pressure (bar)	Weight (kg)	Rolling resistance	Wet Grip	Noise Emission (dB)	Noise Emission (Class)	Vehicle class
														Single	Dual	Single	Dual							
255/70R22.5	HN257	140/137M	140/140L	16	TL	M+S	250	925	435	2824	14.5	7.50 - 22.5	8.25 - 22.5	2500	2300	2500	2500	8.3	42.05	D	C	73	CAT-2	C3
255/70R22.5	HN355	140/137M	140/140L	16	TL	M+S	254	936	435	2855	20.0	7.50 - 22.5	8.25 - 22.5	2500	2300	2500	2500	8.3	44.81	D	C	73	CAT-1	C3
275/70R22.5	HN257	148/145M		18	TL	M+S	272	963	446	2937	15.0	7.50 - 22.5	8.25 - 22.5	3150	2900			9.0	47.15	C	C	73	CAT-2	C3
275/70R22.5	HN355	148/145M		18	TL	M+S	272	972	446	2965	20.0	7.50 - 22.5	8.25 - 22.5	3150	2900			9.0	50.56	D	C	73	CAT-1	C3
275/70R22.5	AGB20	148/145J	152/148E	18	TL	M+S	273	975	446	2973	20.0	7.50 - 22.5	8.25 - 22.5	3150	2900	3550	3150	9.0	50.97	D	C	73	CAT-2	C3
275/70R22.5	AGC28	148/145L		18	TL	M+S	272	968	446	2952	17.5	7.50 - 22.5	8.25 - 22.5	3150	2900			9.0	48.69	E	C	73	CAT-2	C3
275/80R22.5	HN267	149/146L	148/145M	16	TL	M+S	285	1013	473	3129	15.0	7.50 - 22.5	8.25 - 22.5	3250	3000	3150	2900	8.3	52.22	D	C	76	CAT-3	C3
275/80R22.5	HN306	149/146L	148/145M	16	TL	M+S	285	1026	473	3129	20.6	7.50 - 22.5	8.25 - 22.5	3250	3000	3150	2900	8.3	57.02	D	C	76	CAT-3	C3
295/60R22.5	NEO FUEL S	150/147K	149/146L	18	TL	M+S	287	918	427	2800	13.5	9.00 - 22.5	8.25 - 22.5	3350	3075	3250	3000	9.0	47.45	C	D	72	CAT-2	C3
295/60R22.5	NEO FUEL D	150/147K	149/146L	18	TL	M+S	288	926	490	2824	18.0	9.00 - 22.5	8.25 - 22.5	3350	3075	3250	3000	9.0	52.44	D	D	74	CAT-1	C3
295/60R22.5	HN257	149/146L	150/147K	18	TL	M+S	286	918	421	2881	14.5	9.00 - 22.5	8.25 - 22.5	3250	3000	3350	3075	9.0	48.1	D	C	73	CAT-2	C3
295/60R22.5	HN355	149/146L	150/147K	18	TL		288	925	421	2908	22.5	9.00 - 22.5	8.25 - 22.5	3250	3000	3350	3075	9.0	50.16	D	C	73	CAT-1	C3
295/60R22.5	ADL67	149/146L	150/147K	18	TL	M+S	288	926	421	2908	18.0	9.00 - 22.5	8.25 - 22.5	3250	3000	3350	3075	9.0	52.37	E	C	73	CAT-1	C3
295/80R22.5	NEO FUEL S	154/149M		18	TL	M+S	312	1013	490	3090	14.5	9.00 - 22.5	8.25 - 22.5	3750	3250			8.3	58.6	B	B	72	CAT-2	C3
295/80R22.5	NEO FUEL D	154/149M		18	TL	M+S	291	1047	481	3193	18.0	9.00 - 22.5	8.25 - 22.5	3550	3150			9.0	64.57	D	D	74	CAT-1	C3
295/80R22.5	ASR69	154/149M		18	TL	M+S	305	1048	497	3196	15.5	9.00 - 22.5	8.25 - 22.5	3750	3250			9.0	59.9	D	C	71	CAT-2	C3
295/80R22.5	ADR69	152/149M		18	TL	M+S	298	1062	497	3239	22.5	9.00 - 22.5	8.25 - 22.5	3550	3150			9.0	67.23	E	C	74	CAT-2	C3
295/80R22.5	AGB20	152/149J	154/150E	18	TL	M+S	298	1056	497	3221	20.0	9.00 - 22.5	8.25 - 22.5	3550	3250	3750	3350	9.0	66.69	D	C	73	CAT-2	C3
295/80R22.5	NEO WINTER S	154/149M		18	TL	M+S	298	1053	491	3686	15.5	9.00 - 22.5	8.25 - 22.5	3750	3250			9.0	55.99	D	C	74	CAT-2	C3
295/80R22.5	ADW80	152/148M		18	TL	M+S	298	1062	490	3239	24.0	9.00 - 22.5	8.25 - 22.5	3550	3150			7.3	71.35	F	C	73	CAT-1	C3
315/60R22.5	HN227	152/148L		20	TL	M+S	315	944	418	2875	13.0	9.00 - 22.5	9.75 - 22.5	3550	3150			9.0	55.22	D	C	73	CAT-2	C3
315/60R22.5	ADL67	152/148L		20	TL	M+S	315	952	419	2879	18.0	9.00 - 22.5	9.75 - 22.5	3550	3150			9.0	59.69	E	C	73	CAT-1	C3
315/70R22.5	NEO ALLROADS S	156/150L	154/150M	18	TL	M+S	312	1018	465	3105	16.0	9.00 - 22.5	9.75 - 22.5	4000	3350	3750	3350	9.0	59.81	B	B	73	CAT-2	C3
315/70R22.5	NEO ALLROADS D+	152/148M	154/150L	18	TL	M+S	281	1023	473	3120	21.0	9.00 - 22.5	9.75 - 22.5	3550	3150	3750	3350	9.0	65.86	D	B	73	CAT-1	C3
315/70R22.5	NEO FUEL S	156/150L	154/150M	18	TL	M+S	313	1014	471	3093	14.5	9.00 - 22.5	9.75 - 22.5	4000	3350	3750	3350	9.0	58.31	B	B	72	CAT-2	C3
315/70R22.5	NEO FUEL D	154/150L	152/148M	18	TL	M+S	318	1023	473	3120	18.0	9.00 - 22.5	9.75 - 22.5	3750	3350	3550	3150	8.3	63.66	C	B	74	CAT-1	C3
315/70R22.5	ASR69	156/150L	154/150M	18	TL	M+S	312	1018	465	3105	16.5	9.00 - 22.5	9.75 - 22.5	4000	3350	3750	3350	8.3	60.3	D	C	72	CAT-2	C3
315/70R22.5	ADR69	152/148M	154/150L	18	TL	M+S	312	1030	465	3142	23.0	9.00 - 22.5	9.75 - 22.5	3550	3150	3750	3350	8.3	66.62	D	C	74	CAT-2	C3
315/70R22.5	ADL67	152/148M	154/150L	18	TL	M+S	316	1019	465	3200	18.0	9.00 - 22.5	9.75 - 22.5	3550	3150	3750	3350	8.3	64.72	C	C	73	CAT-1	C3
315/70R22.5	ASW80	152/148M	154/150L	18	TL	M+S	302	1014	464	3093	16.5	9.00 - 22.5	9.75 - 22.5	3550	3150	3750	3350	8.3	61.72	D	C	73	CAT-2	C3
315/70R22.5	ADW80	152/148M	154/150L	18	TL	M+S	312	1032	475	3148	24.0	9.00 - 22.5	9.75 - 22.5	3550	3150	3750	3350	7.3	72.33	F	C	73	CAT-1	C3
315/80R22.5	NEO FUEL S	158/150L	154/150M	18	TL	M+S	318	1080	478	3294	14.0	9.00 - 22.5	9.75 - 22.5	4250	3350	3750	3350	8.3	66.36	B	B	72	CAT-2	C3
315/80R22.5	NEO FUEL D	156/150L	154/150M	18	TL	M+S	318	1088	483	3318	18.0	9.00 - 22.5	9.75 - 22.5	4000	3350	3750	3350	8.3	71.65	C	B	74	CAT-1	C3
315/80R22.5	ASR69	158/150L	154/150M	18	TL	M+S	315	1080	490	3394	16.5	9.00 - 22.5	9.75 - 22.5	4250	3350	3750	3350	8.3	66.65	C	C	72	CAT-2	C3
315/80R22.5	ADR69	154/150M	156/150L	18	TL	M+S	315	1084	490	3306	23.0	9.00 - 22.5	9.75 - 22.5	3750	3350	4000	3350	9.0	74.09	D	C	74	CAT-2	C3
315/80R22.5	ADL67	154/151M	156/150L	18	TL	M+S	319	1084	490	3306	18.0	9.00 - 22.5	9.75 - 22.5	3750	3450	4000	3350	8.3	71.77	D	C	73	CAT-1	C3
315/80R22.5	AGC51	154/151L	156/150K	18	TL	M+S	314	1081	488	3297	16.5	9.00 - 22.5	9.75 - 22.5	3750	3450	4000	3350	8.3	67.67	C	C	73	CAT-2	C3
315/80R22.5	HN08	154/151L	156/150K	18	TL	M+S	315	1084	490	3306	16.5	9.00 - 22.5	9.75 - 22.5	3750	3450	4000	3350	9.0	67.67	C	C	71	CAT-2	C3
315/80R22.5	ADC53	154/151M	156/150L	18	TL	M+S	315	1088	490	3318	19.5	9.00 - 22.5	9.75 - 22.5	3750	3450	4000	3350	8.3	70.95	C	C	73	CAT-1	C3
315/80R22.5	HN352	156/150K		18	TL	M+S	315	1094	490	3337	23.0	9.00 - 22.5	9.75 - 22.5	4000	3350			8.3	73.04	D	B	72	CAT-1	C3
315/80R22.5	ASW80	154/151M	156/150L	18	TL	M+S	314	1078	492	3288	16.5	9.00 - 22.5	9.75 - 22.5	3750	3450	4000	3350	8.3	68.45	D	C	73	CAT-2	C3
315/80R22.5	ADW80	154/151M	156/150L	18	TL	M+S	315	1096	495	3343	24.0	9.00 - 22.5	9.75 - 22.5	3750	3450	4000	3350	7.3	78.75	F	C	73	CAT-1	C3
385/55R22.5	NEO ALLROADS S+	160K	158L	20	TL	M+S	386	1004	461	3151	16.5	11.75 - 22.5	12.25 - 22.5	4500		4250		9.0	71.3	B	C	73	CAT-2	C3
385/55R22.5	ATR65	160J	158L	20	TL	M+S	386	1004	461	3151	16.5	11.75 - 22.5	12.25 - 22.5	4500		4250		9.0	71.3	C	C	73	CAT-2	C3
385/55R22.5	AGC28	160K	158L	20	TL	M+S	386	1004	461	3151	17.0	11.75 - 22.5	12.25 - 22.5	4500		4250		9.0	73.9	C	C	73	CAT-1	C3
385/55R22.5	ASW80	160K	158L	20	TL	M+S	385	1004	455	3042	13.5	11.75 - 22.5	12.25 - 22.5	4500		4250		8.3	71.23	D	C	73	CAT-2	C3
385/65R22.5	NEO ALLROADS S+	164K	158L	20	TL	M+S	383	1086	497	3312	16.8	11.75 - 22.5	12.25 - 22.5	5000		4250		9.0	74.49	B	A	73	CAT-2	C3
385/65R22.5	NEO ALLROADS T+	164K	158L	20	TL	M+S	380	1077	498	3285	17.0	11.75 - 22.5	12.25 - 22.5	5000		4250		9.3	76.75	B	C	73	CAT-2	C3
385/65R22.5	ATR65	160K	158L	20	TL	M+S	385	1070	491	3242	16.8	11.75 - 22.5	12.25 - 22.5	4500		4250		9.0	77.75	B	C	73	CAT-2	C3
385/65R22.5	ATR65+	164K		20	TL	M+S	385	1070	491	3242	16.8	11.75 - 22.5	12.25 - 22.5	5000				9.0	77.75	B	C	73	CAT-2	C3
385/65R22.5	AGC28	160K	158L	20	TL	M+S	385	1070	491	3242	16.8	11.75 - 22.5	12.25 - 22.5	4500		4250		9.0	75.91	C	C	73	CAT-1	C3
385/65R22.5	HN207	164K		20	TL	M+S	385	1068	491	3236	16.0	11.75 - 22.5	12.25 - 22.5	4500				9.0	100.0	C	C	76	CAT-3	C3
385/65R22.5	HN809	160K	158L	20	TL	M+S	385	1064	491	3224	15.0	11.75 - 22.5	12.25 - 22.5	4500		4250		9.0	100.0	C	C	76	CAT-3	C3
385/65R22.5																								

OUR TOTAL CONCEPT AT THE LOWEST TOTAL COST

Real costs are important to transport companies. This is something we fully realise. We thus try to minimise costs by developing top quality tyres that offer a long life-span, such as the Aeolus Life Cycle. Let's take our new Aeolus truck tyre as an example. When these tyres reach the end of their service life (in good condition), regrooving can be used to extend their life-span. Thanks to a high rubber percentage, tyre specialists can easily prolong use by cutting 3 mm deeper into the tyre. After regrooving, Aeolus Casing Management & high quality tread renewal are other important tools for extending life-span and reducing costs.

Regrooving

Re-profiling is possible on Aeolus tyres which, in accordance with ECE regulation 54, feature the word 'REGROOVABLE' on both side walls. In addition, they must, in accordance with §36 Erläuterung 6 StVZO 4.2 (German road authorisation), have a remaining pattern depth of at least 2 mm. We recommend re-profiling when the remaining pattern depth is 3 mm. Irregular wear and blocking points must also be taken into account when doing so. The tyres can only be re-profiled by a qualified specialist, so the option of tread renewal is not put at risk.

NEO ALLROADS S

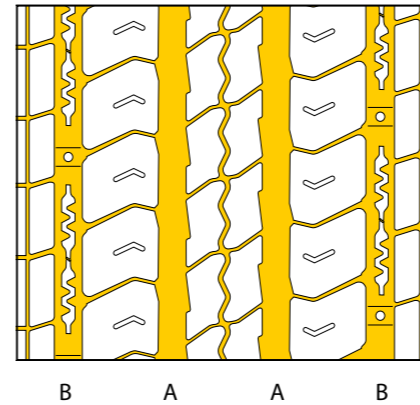

Size	Depth (mm)	Width (mm)
205/75R17.5	A:3;B:2	7-8
215/75R17.5	A:2.5;B:2	7-8
225/75R17.5	A:3;B:2	7-8
235/75R17.5	A:3;B:2	7-8
245/70R17.5	A:3;B:2	7-8
265/70R19.5	A:3;B:2	7-8
295/60R22.5	A:3-3.5;B:2-2.5	10-12
295/80R22.5	A:3-3.5;B:2-2.5	10-12
315/70R22.5	A:3-3.5;B:2-2.5	10-12
315/80R22.5	A:3-3.5;B:2-2.5	10-12

NEO ALLROADS S+

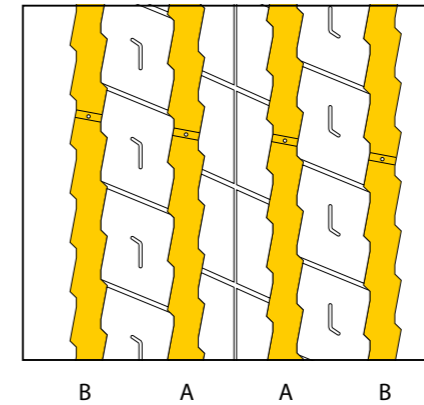

Size	Depth (mm)	Width (mm)
385/55R22.5	A:3-3.5;B:2-2.5	A:10-12;B:5-7
385/65R22.5	A:3-3.5;B:2-2.5	A:10-12;B:5-7

NEO ALLROADS D

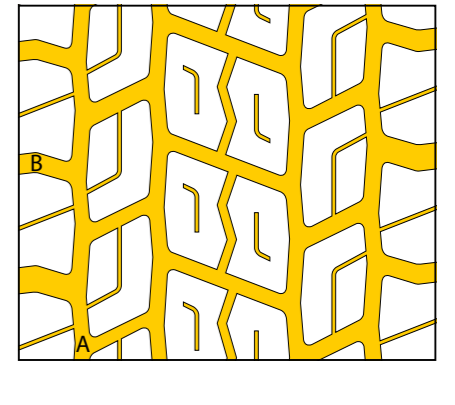

Size	Depth (mm)	Width (mm)
205/75R17.5	2-2.5	A:7-8;B:5-8
215/75R17.5	2	A:7-8;B:5-7
225/75R17.5	2-2.5	A:7-8;B:5-7
235/75R17.5	2-2.5	A:7-8;B:5-7
245/70R17.5	2-2.5	A:9-11;B:5-7
265/70R19.5	2-2.5	A:7-9;B:3-5
285/70R19.5	2-2.5	A:7-9;B:3-5

NEO CONSTRUCT G

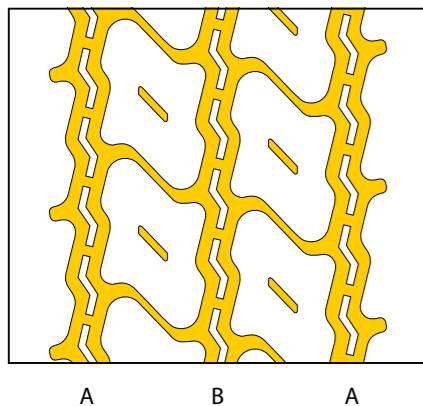

Size	Depth (mm)	Width (mm)
13R22.5	A:3-3.5;B:2-2.5	10-12
315/80R22.5	A:3-3.5;B:2-2.5	10-12
385/65R22.5	A:3-3.5;B:2-2.5	10-12
425/65R22.5	A:3-3.5;B:2-2.5	10-12
445/65R22.5	A:3-3.5;B:2-2.5	10-12
325/95R224	A:3-3.5;B:2-2.5	10-12

NEO CONSTRUCT D

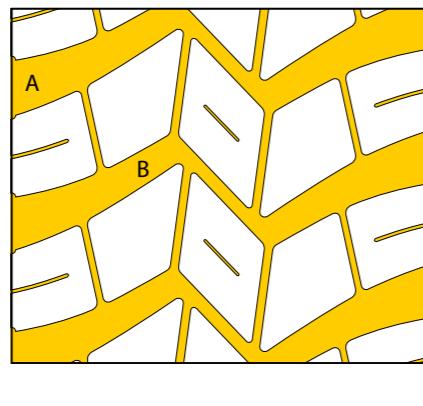

Size	Depth (mm)	Width (mm)
13R22.5	2.5	A:10-12;B:5-7
315/80R22.5	2-2.5	A:10-12;B:5-7
325/95R224	2-2.5	A:10-12;B:5-7

NEO URBAN G

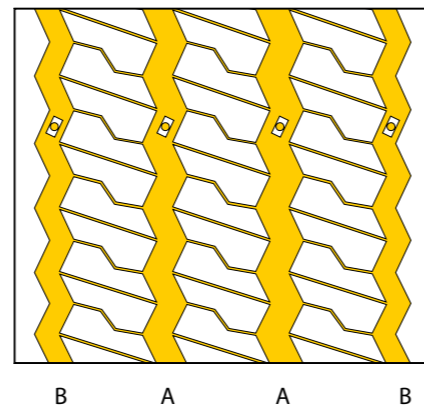

Size	Depth (mm)	Width (mm)
11R22.5	A;4 B;3	7-8
275/70R22.5	A;4 B;3	7-8
295/80R22.5	A;4 B;3	7-8

NEO ALLROADS D+

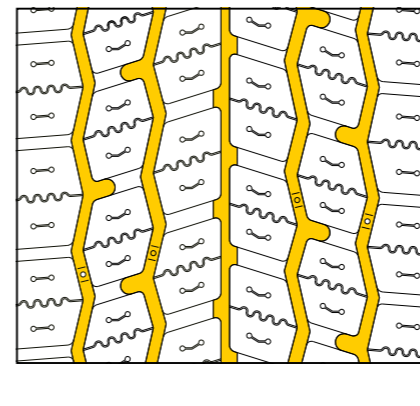

Size	Depth (mm)	Width (mm)
295/60R22.5	2-2.5	5-7
295/80R22.5	2-2.5	5-7
315/60R22.5	2-2.5	5-7
315/70R22.5	2-2.5	5-7
315/80R22.5	2-2.5	5-7

NEO ALLROADS T

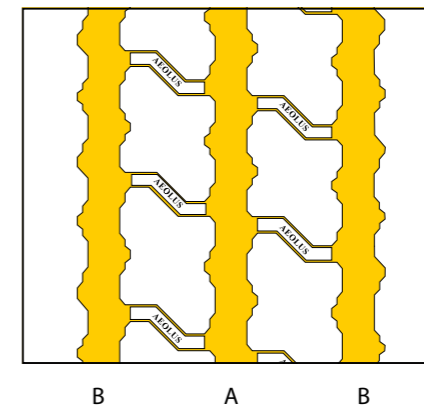

Size	Depth (mm)	Width (mm)
205/65R17.5	A:2.5;B:2	7-8
215/75R17.5	A:2.5;B:2	7-8
235/75R17.5	A:3;B:2	7-8
245/70R17.5	A:3;B:2	7-8
265/70R17.5	A:3;B:2	7-8

NEO ALLROADS T+

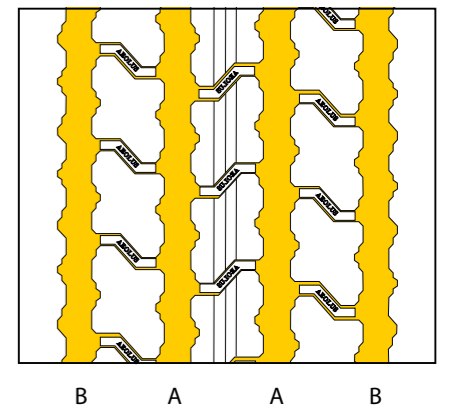

Size	Depth (mm)	Width (mm)
285/70R19.5	A:3;B:2	7-9
385/55R22.5	A:3-3.5;B:2-2.6	7-8
385/65R22.5	A:3-3.5;B:2-2.5	7-8
425/65R22.5	A:3-3.5;B:2-2.6	7-8
445/65R22.5	A:3-3.5;B:2-2.5	7-8

NEO FUEL S

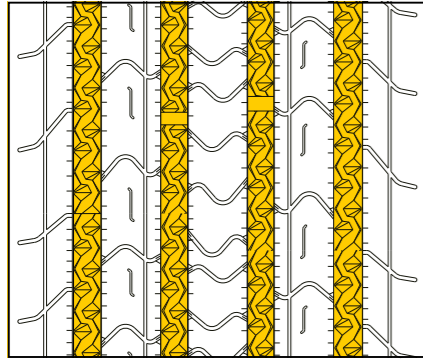

B A A B

Size	Depth (mm)	Width (mm)
295/60R22.5	A:2.5;B:2	5-6
295/80R22.5	A:3-3.5;B:2-2.5	5-6
315/60R22.5	A:3-3.5;B:2-2.5	5-6
315/70R22.5	A:3-3.5;B:2-2.5	5-6
315/80R22.5	A:3-3.5;B:2-2.5	5-6

NEO FUEL D

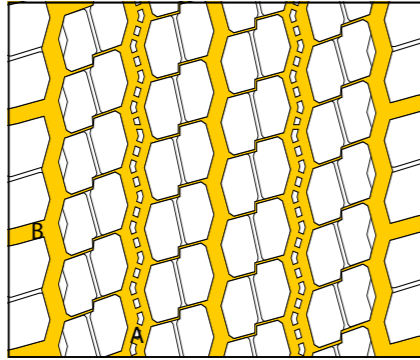

B A

Size	Depth (mm)	Width (mm)
295/60R22.5	A:2.5-3;B:2-2.5	A:10-12;B:5-7
295/80R22.5	A:3-3.5;B:2-2.5	A:10-12;B:5-7
315/60R22.5	A:3-3.5;B:2-2.5	A:10-12;B:5-7
315/70R22.5	A:3-3.5;B:2-2.5	A:10-12;B:5-7
315/80R22.5	A:3-3.5;B:2-2.5	A:10-12;B:5-7

NEO FUEL T+

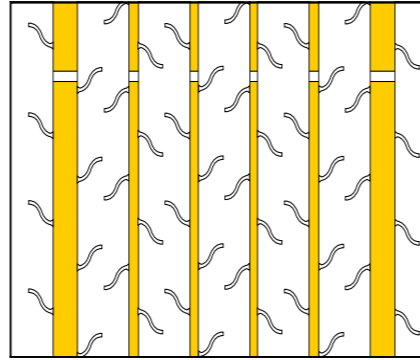

B A A A A B

Size	Depth (mm)	Width (mm)
385/55R19.5	A:3, B:3	A: 3, B:7-8
435/50R19.5	A:3, B:3	A: 3, B:7-8
445/45R19.5	A:3, B:3	A: 3, B:7-8
385/65R22.5	A:3, B:3	A: 3, B:7-8

ASR69

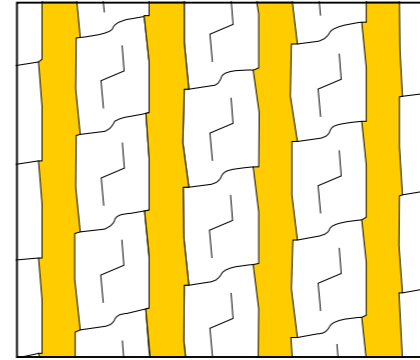

B A A B

Size	Depth (mm)	Width (mm)
295/80R22.5	A:3-3.5;B:2-2.5	10-12
315/70R22.5	A:3-3.5;B:2-2.5	10-12
315/80R22.5	A:3-3.5;B:2-2.5	10-12

ADR69

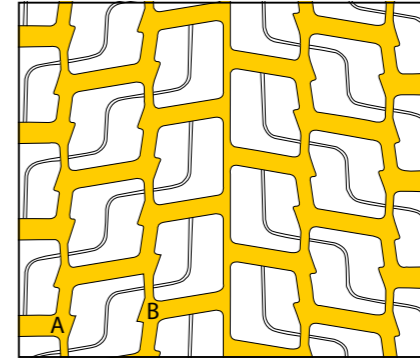

A B

Size	Depth (mm)	Width (mm)
295/80R22.5	2-2.5	A:10-12;B:5-7
315/70R22.5	2-2.5	A:10-12;B:5-7
315/80R22.5	2-2.5	A:10-12;B:5-7

ATR65

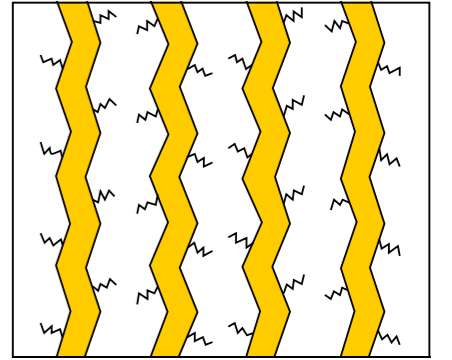

B A A B

Size	Depth (mm)	Width (mm)
245/70R17.5	A:2.5;B:2	7-9
285/70R19.5	A:3;B:2	7-9
265/70R19.5	A:3;B:2	7-9
385/55R22.5	A:3-3.5;B:2-2.6	7-9
385/65R22.5	A:3-3.5;B:2-2.5	7-9
425/65R22.5	A:3-3.5;B:2-2.6	7-9
445/65R22.5	A:3-3.5;B:2-2.5	7-9

NEO WINTER S

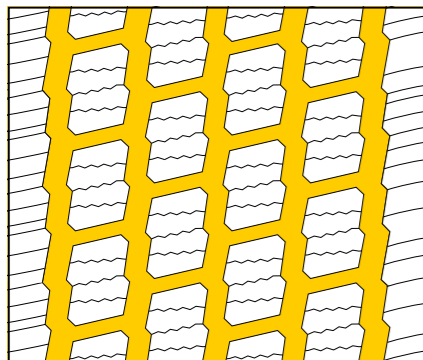

B A A A B

Size	Depth (mm)	Width (mm)
295/60R22.5	A:3-3.5;B:2-2.5	10-12
295/80R22.5	A:3-3.5;B:2-2.5	10-12
315/60R22.5	A:3-3.5;B:2-2.5	10-12
315/70R22.5	A:3-3.5;B:2-2.5	10-12
315/80R22.5	A:3-3.5;B:2-2.5	10-12
385/55R22.5	A:3-3.5;B:2-2.5	10-12
385/65R22.5	A:3-3.5;B:2-2.5	10-12

NEO WINTER D

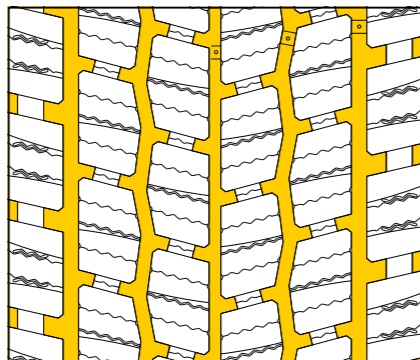

B A

Size	Depth (mm)	Width (mm)
295/60R22.5	2-2.5	5-7
295/80R22.5	2-2.5	5-7
315/60R22.5	2-2.5	5-7
315/70R22.5	2-2.5	5-7
315/80R22.5	2-2.5	5-7

AGC28

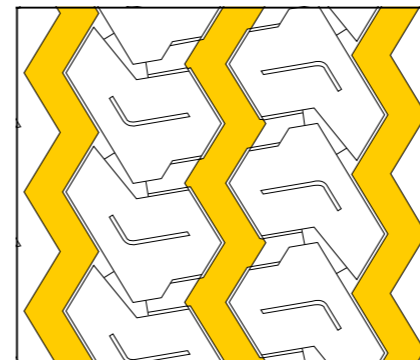

B A B

Size	Depth (mm)	Width (mm)
215/75R17.5	A:2.5;B:2	7-8
235/75R17.5	A:3;B:2	7-8
245/70R17.5	A:3;B:2	7-8
265/70R19.5	A:3;B:2	10-11
275/70R22.5	A:3-3.5;B:2-2.5	10-12
385/55R22.5	A:3-3.5;B:2-2.5	10-12
385/65R22.5	A:3-3.5;B:2-2.5	7-8
425/65R22.5	A:3-3.5;B:2-2.5	10-12
445/65R22.5	A:3-3.5;B:2-2.5	10-12

ADC53

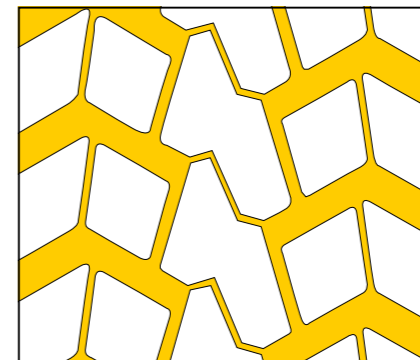

A B

Size	Depth (mm)	Width (mm)
11R22.5	2.5	A:10-12;B:5-7
12R22.5	2.5	A:10-12;B:5-7
13R22.5	2.5	A:10-12;B:5-7
315/80R22.5	2-2.5	A:10-12;B:5-7
12.00R24	2.5	A:10-12;B:5-7

ADL67

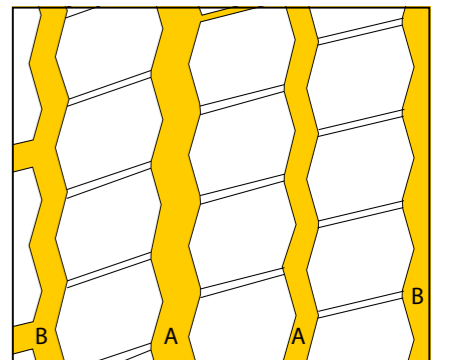

B A A B

Size	Depth (mm)	Width (mm)
295/60R22.5	A:2.5-3;B:2-2.5	A:10-12;B:5-7
295/80R22.5	A:3-3.5;B:2-2.5	A:10-12;B:5-7
315/60R22.5	A:2.5-3;B:2-2.5	A:10-12;B:5-7
315/70R22.5	A:3-3.5;B:2-2.5	A:10-12;B:5-7
315/80R22.5	A:3-3.5;B:2-2.5	A:10-12;B:5-7

8.25R15	HN230+	M+S	TT Set	143/141G (141/140J)
10.00R15	HN230+	M+S	TT Set	148/145G (146/144J)
7.50R16	HN08	M+S	TT Set	122/118L
8.25R16	HN08	M+S	TT Set	126/122L
9.5R17.5	ASR24	M+S	TL	129/127M
9.5R17.5	ADR35	M+S	TL	129/127M
205/65R17.5	NEO Allroads T	M+S	TL	129/127J (132/132F)
205/75R17.5	ASR35	M+S	TL	124/122M
205/75R17.5	ADR35	M+S	TL	124/122M
215/75R17.5	ASR35	M+S	TL	127/124M
215/75R17.5	ADR35	M+S	TL	127/124M
215/75R17.5	ATL35	M+S	TL	135/133J
215/75R17.5	AGC28	M+S	TL	135/133J
225/75R17.5	ASR35	M+S	TL	129/127M
225/75R17.5	ADR35	M+S	TL	129/127M
235/75R17.5	ASR35	M+S	TL	132/129M
235/75R17.5	ADR35	M+S	TL	132/129M
235/75R17.5	ATL35	M+S	TL	143/141J (144/144F)
235/75R17.5	NEO Allroads T	M+S	TL	143/141J (144/144F)
235/75R17.5	AGC28	M+S	TL	143/141J (144/144F)
245/70R17.5	ASR35	M+S	TL	136/134M
245/70R17.5	ADR35	M+S	TL	136/134M
245/70R17.5	ATR65	M+S	TL	143/141J (146/146F)
245/70R17.5	AGC28	M+S	TL	143/141J (144/144F)
245/70R19.5	HN366+	M+S	TL	136/134M (136/135J)
245/70R19.5	HN828+	M+S	TL	141/140J
265/70R19.5	HN257	M+S	TL	140/138M
265/70R19.5	HN355	M+S	TL	140/138M
265/70R19.5	ATR65	M+S	TL	143/141J
265/70R19.5	AGC28	M+S	TL	143/141J
285/70R19.5	HN257	M+S	TL	144/142M (145/143L)
285/70R19.5	ADR35	M+S	TL	144/142M (145/143L)
285/70R19.5	NEO Allroads D	M+S	TL	144/142M (145/143L)
285/70R19.5	ATR65	M+S	TL	150/147J
285/70R19.5	NEO Allroads T+	M+S	TL	150/147J
385/55R19.5	ATR65	M+S	TL	156J
435/50R19.5	HN829	M+S	TL	160J
435/50R19.5	NEO Fuel T+	M+S	TL	164J
445/45R19.5	HN829	M+S	TL	160J
8.25R20	HN08	M+S	TT Set	136/134K
9.00R20	HN08	M+S	TT Set	144/142K
10.00R20	HN08	M+S	TT Set	146/143K
11.00R20	HN08	M+S	TT Set	149/145K
12.00R20	HN08	M+S	TT Set	154/149K

Size	Pattern	M+S		TL/TT	L/S Index
12.00R20	ADC53	M+S		TT Set	154/151K
9R22.5	ASL06	M+S		TL	136/134M
10R22.5	HN257	M+S		TL	144/142M
10R22.5	HN355	M+S		TL	144/142M
11R22.5	HN257	M+S		TL	146/143M
11R22.5	HN08	M+S		TL	146/143L
11R22.5	ADC53	M+S		TL	146/143L
11R22.5	AGB20+	M+S		TL	148/145J (151/148E)
12R22.5	HN257	M+S		TL	152/149M
12R22.5	HN08	M+S		TL	152/149L
12R22.5	HN355	M+S		TL	152/149M
12R22.5	ADC53	M+S		TL	152/149L
13R22.5	AGC51	M+S		TL	154/151L (156/150K)
13R22.5	HN253	M+S		TL	154/151L (156/150K)
13R22.5	HN352	M+S		TL	154/151K (156/150G)
13R22.5	ADC53	M+S		TL	154/151K (156/150G)
13R22.5	HN10	M+S		TL	154/151G (156/150F)
255/70R22.5	HN257	M+S		TL	140/137M (140/140L)
255/70R22.5	HN355	M+S		TL	140/137M (140/140L)
275/70R22.5	HN257	M+S		TL	148/145M
275/70R22.5	HN355	M+S		TL	148/145M
275/70R22.5	AGC28	M+S		TL	148/145L
275/70R22.5	AGB20	M+S		TL	148/145J (152/148E)
275/70R22.5	NEO Urban G	M+S		TL	148/145J (152/148E)
275/80R22.5	HN267	M+S		TL	149/146L (148/145M)
275/80R22.5	HN306	M+S		TL	149/146L (148/145M)
295/60R22.5	NEO Fuel S	M+S		TL	149/146L (150/147K)
295/60R22.5	NEO Fuel D	M+S		TL	149/146L (150/147K)
295/60R22.5	HN257	M+S		TL	149/146L (150/147K)
295/60R22.5	HN355	M+S		TL	149/146L (150/147K)
295/60R22.5	ADL67	M+S		TL	149/146L (150/147K)
295/80R22.5	NEO Fuel S HL	M+S		TL	154/149M
295/80R22.5	NEO Fuel D	M+S		TL	152/148M
295/80R22.5	ASR69 HL	M+S		TL	154/149M
295/80R22.5	ADR69	M+S		TL	152/148M
295/80R22.5	AGB20	M+S		TL	152/148J (154/150E)
295/80R22.5	NEO Winter S HL	M+S		TL	154/149M
295/80R22.5	ADW80	M+S		TL	152/148M
305/70R22.5	AGB22	M+S		TL	152/150L
315/60R22.5	HN227	M+S		TL	152/148L
315/60R22.5	ADL67	M+S		TL	152/148L
315/70R22.5	NEO Allroads S HL	M+S		TL	156/150L (154/150M)
315/70R22.5	NEO Allroads D+	M+S		TL	152/148M (154/150L)
315/70R22.5	NEO Fuel S HL	M+S		TL	156/150L (154/150M)
315/70R22.5	NEO Fuel D	M+S		TL	152/148M (154/150L)
315/70R22.5	ASR69 HL	M+S		TL	156/150L (154/150M)
315/70R22.5	ADR69	M+S		TL	152/148M (154/150L)
315/70R22.5	ADL67	M+S		TL	152/148M (154/150L)

Size	Pattern	M+S		TL/TT	L/S Index
315/70R22.5	ASW80	M+S		TL	152/148M (154/150L)
315/70R22.5	NEO Winter D	M+S		TL	152/148M (154/150L)
315/80R22.5	NEO Fuel S HL	M+S		TL	158/150L (154/150M)
315/80R22.5	NEO Fuel D	M+S		TL	154/150M (156/150L)
315/80R22.5	ASR69 HL	M+S		TL	158/150L (154/150M)
315/80R22.5	ADR69	M+S		TL	154/150M (156/150L)
315/80R22.5	ADL67	M+S		TL	154/150M (156/150L)
315/80R22.5	AGC51	M+S		TL	154/150L (156/150K)
315/80R22.5	HN08	M+S		TL	154/150L (156/150K)
315/80R22.5	ADC53	M+S		TL	154/150M (156/150L)
315/80R22.5	HN352	M+S		TL	156/150K
315/80R22.5	ASW80	M+S		TL	154/150M (156/150L)
315/80R22.5	ADW80	M+S		TL	154/150M (156/150L)
385/55R22.5	NEO Allroads T+	M+S		TL	160J (158L)
385/55R22.5	ATR65	M+S		TL	160J (158L)
385/55R22.5	AGC28	M+S		TL	160K (158L)
385/55R22.5	ASW80	M+S		TL	160K (158L)
385/65R22.5	NEO Allroads T+HL	M+S		TL	164K (158L)
385/65R22.5	NEO Allroads S+HL	M+S		TL	164K (158L)
385/65R22.5	ATR65	M+S		TL	160K (158L)
385/65R22.5	ATR65+ HL	M+S		TL	164K (158L)
385/65R22.5	AGC28	M+S		TL	160K (158L)
385/65R22.5	HN207 HL	M+S		TL	164K (158L)
385/65R22.5	HN809	M+S		TL	160K (158L)
385/65R22.5	NEO Winter S+HL	M+S		TL	164K (158L)
425/65R22.5	NEO Allroads T+	M+S		TL	165K
425/65R22.5	ATR65	M+S		TL	165K
425/65R22.5	AGC28	M+S		TL	165K
445/65R22.5	NEO Allroads T+	M+S		TL	169 K
445/65R22.5	ATR65	M+S		TL	169 K
445/65R22.5	AGC28	M+S		TL	169 K
12.00R24	AGC51	M+S		TT Set	160/157K
12.00R24	HN08	M+S		TT Set	160/157K
12.00R24	ADC53	M+S		TT Set	160/157K

AEOLUS-TYRES.COM

AEOLUS
NO MATTER WHAT